

Multi-Purpose Subplates

40x20 Multi-Purpose Subplate

Part Number	Wt (lbs)
49112	285

The Jergens Multi-Purpose Subplate accommodates a wide variety of fixture plates and vises. This versatility facilitates using the same VMC for diverse products in repetitive runs, long and short batch sizes.

- FreMax™ 15 Steel or Equivalent
- Thickness: 1 1/4" ±0.005"
- Parallel within 0.001"

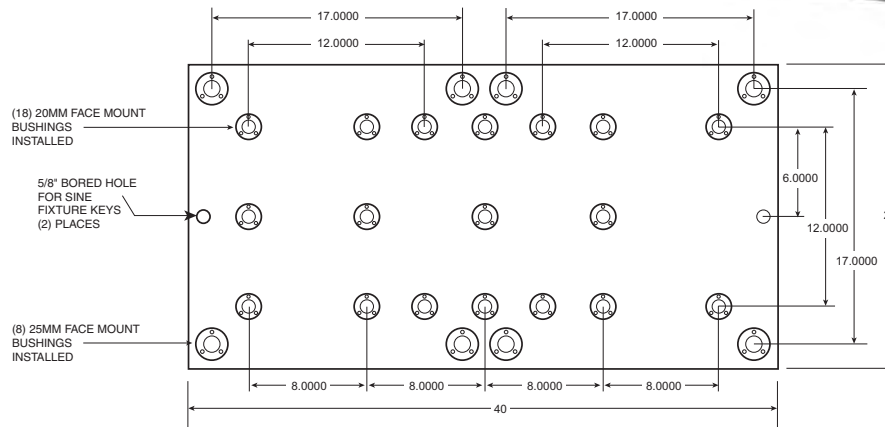
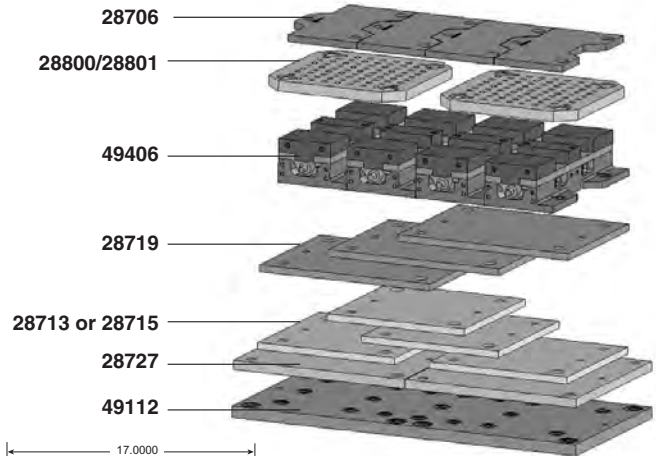

Fixture Plate Options for Multi-Purpose Subplates – Aluminum or Steel

Fixture Plate*/Vise Part Number	Thickness of Fixture Plate	Number of Fixture Plates/Vises That Mount on Multi-Purpose Subplate	Receiver Bushing Center Distance	Receiver Bushing Size	Required Ball Lock® Shank Part Number	Number of Shanks Required Per Fixture Plate/Vise
28713 (14 x 14) Fixture Plate	3/4"	2	12 x 12	20 mm	49601	4
28715 (16 x 16) Fixture Plate	3/4"	2	12 x 12	20 mm	49601	4
28800 (16 x 16) Modular Grid Plate	1 1/8" **	2	12 x 12	20 mm	49601	4
28801 (16 x 16) Modular Grid Plate	1 1/8" ***	2	12 x 12	20 mm	49602	4
28706 Jigsaw Interlocking Plate	3/4"	4	8 x 12	20 mm	49601	3
28727 (20 x 20) Fixture Plate	1"	2	17 x 17	25 mm	49612	4
28719 (20 x 16) Fixture Plate	3/4"	1	16 x 12	20 mm	49601	4
49406 6" Jigsaw Base Vise	3/4"	4	8 x 12	20 mm	49601	3

*See next page for dimensional data on fixture plates. Part numbers shown for aluminum plates, also available in steel.

**Counterbored to 3/4" at mounting holes.

***Counterbored to 1" at mounting holes.

Fixture Plates

14x14x3/4" Fixture Plate

Aluminum Plate Part Number	Wt (lbs)	Steel Plate Part Number	Wt (lbs)
28713	14	28813	42

16x16x3/4" Fixture Plate

Aluminum Plate Part Number	Wt (lbs)	Steel Plate Part Number	Wt (lbs)
28715	18	28815	55

- Cast Aluminum or FreMax™ 15 Steel or equivalent
- Thickness: 3/4" ±0.005"
- Parallel within 0.001" Steel
- Mounts to subplates with Ball Lock® Shank 49601 (20 x 3/4")

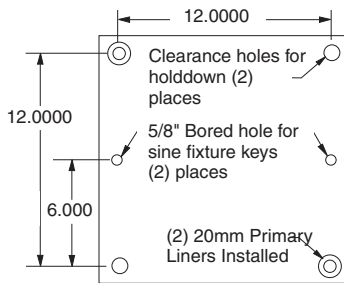

16x16 Modular Grid Fixture Plate

Part No.	A ±.005 (in)	Wt. (lbs)	Shank Part No.
28800	0.75	70	49601
28801	1.00	80	49602

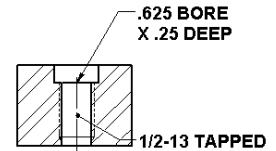

- FreMax™ 15 Steel or equivalent
- Thickness: 1 1/8" ±0.005"
- Parallel within 0.001"

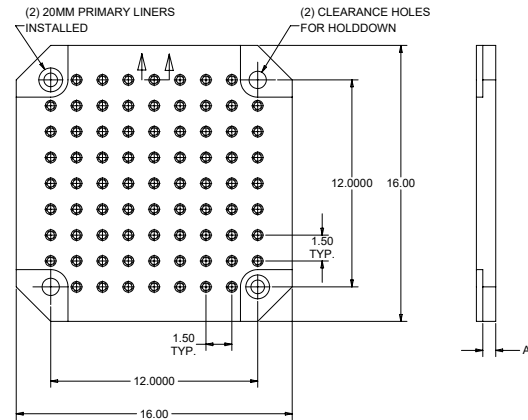

Jigsaw Interlocking Fixture Plate

Aluminum Plate Part No	Wt. (lbs)	Steel Plate Part No	Wt. (lbs)	A (in)	B (in)	C (in)	D (in)	Jergens Vise P/N
28705	6	28805	19	7.97	5.97	15.00	6.00	49401
28706	11	28806	34	9.97	7.97	16.00	8.00	49402

- Cast Aluminum or FreMax™ 15 Steel or equivalent
- Thickness: 3/4" ±0.005"
- Parallel within 0.001" Steel
- For use with narrow base 4" or 6" vise models
- Design allows close vise spacing for more parts per run
- Easily mounts to Subplates using the Ball Lock® Shank 49601 (20 x 3/4")
- Useful for high density fixturing of small parts

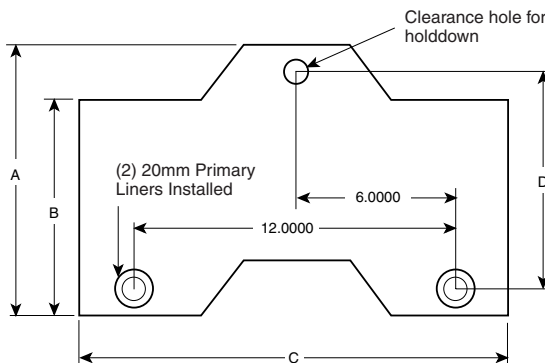

20x20x1" Fixture Plate

Aluminum Plate Part Number	Wt. (lbs)	Steel Plate Part Number	Wt. (lbs)
28727	38	28827	114

- Cast Aluminum or FreMax™ 15 Steel or equivalent
- Thickness: 1" ±0.005"
- Parallel within 0.001" Steel
- Mounts to subplates with Ball Lock® Shank 49612 (25 x 1")

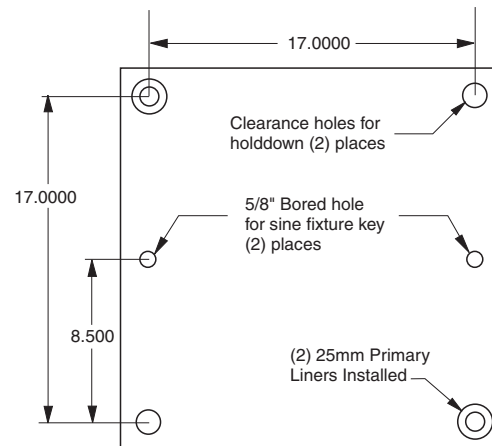

QUICK CHANGE FIXTURING » BALL LOCK® MOUNTING SYSTEM

Ball Lock® Fixture Plates

- Cast Aluminum or FreeMax™ 15 Steel or equivalent
- Thickness tolerance $\pm 0.005"$
- Parallel within 0.001" Steel
- 6061-T-651 Aluminum plates, within .001 available upon request

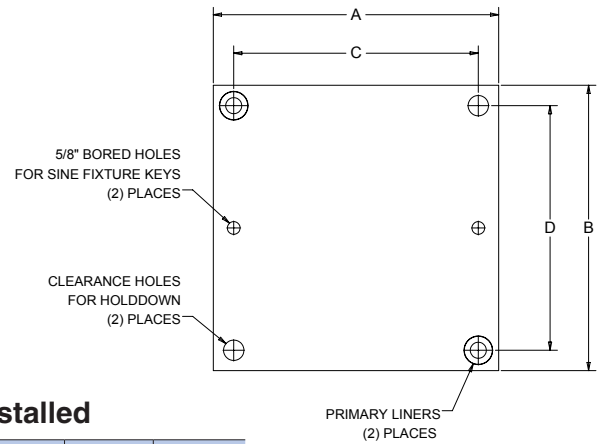

Ball Lock® Fixture Plates with 2 Primary Liners Installed

Part No. Aluminum	Wt. (lbs)	Part No. Steel	Wt. (lbs)	A (in)	B (in)	C (in)	D (in)	Thickness (in) $\pm .005$	Liner Size (mm)	Shank Part No.
28711	12	28811	36	12	14	9	12	0.75	20	49601
28713	14	28813	42	14	14	12	12	0.75	20	49601
28714	19	28814	54	14	14	12	12	1.00	20	49602
28715	18	28815	55	16	16	12	12	0.75	20	49601
28716	24	28816	73	16	16	12	12	1.00	20	49602
28717	18	28817	55	16	16	14	14	0.75	20	49601
28719	23	28819	68	20	16	16	12	0.75	20	49601
28722	16	28822	48	12	14	9	12	1.00	25	49612
28724	19	28824	56	14	14	12	12	1.00	25	49612
28726	24	28826	73	16	16	12	12	1.00	25	49612
28727	38	28827	114	20	20	17	17	1.00	25	49612
28731	11	28831	32	15	10	12	8	0.75	16	49608
28732	58	28832	117	25	25	21	21	1.00	35	49632

- Machined to close tolerances
- Repeatability $\pm 0.0005"$ or better
- Reduces fixture set-up and assembly time
- Provided with 5/8" bored holes for sine fixture keys
- For horizontal or vertical machining centers, Tool Room Mills, or multiple pallet machining centers

Custom Sizes Available

Jergens will make Ball Lock® fixture plate or subplates to your specifications. Call 1-877-426-2504 for further information.

15x10x3/4" Fixture Plate Bridgeport™ Style

Aluminum Plate Part Number	Wt (lbs)	Steel Plate Part Number	Wt (lbs)
28731	11	28831	32

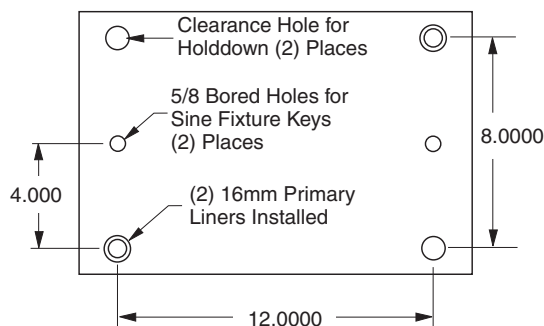

12x14x3/4" Fixture Plate

Aluminum Plate Part Number	Wt (lbs)	Steel Plate Part Number	Wt (lbs)
28711	12	28811	36

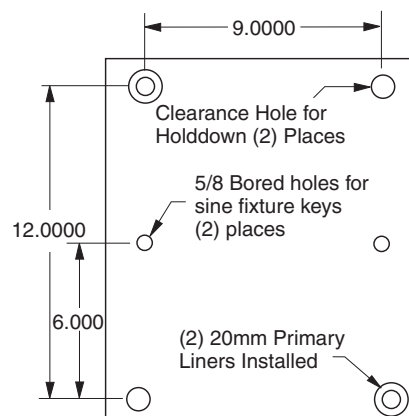

16x16 QLS Fixture Plate

Steel Plate Part Number	Wt (lbs)
28802	84

- FreMax™ 15 Steel or equivalent
- Thickness: 1.378" ± 0.002"
- Parallel within 0.001"
- Mounts to subplates with Ball Lock® Shank 49601 (20 x 3/4")

★ = Jergens QLS
 Quick Locating System (QLS) Bushings are hardened and ground for accurate and repeatable setups. Use in combination with 12mm QLS dowel pins or shoulder screws.

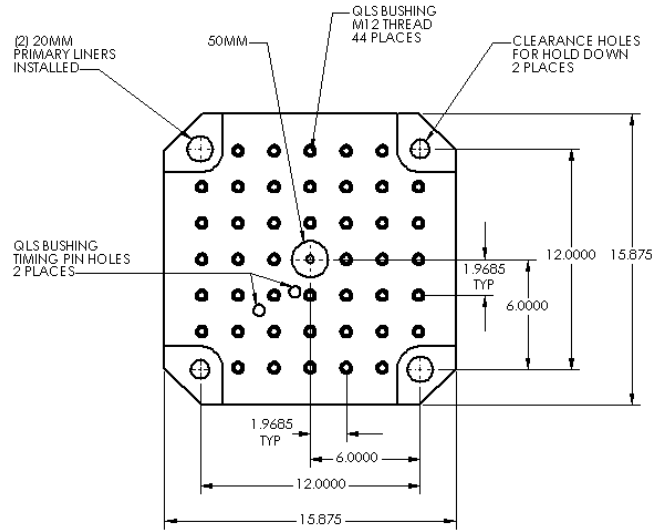

Configuration Options

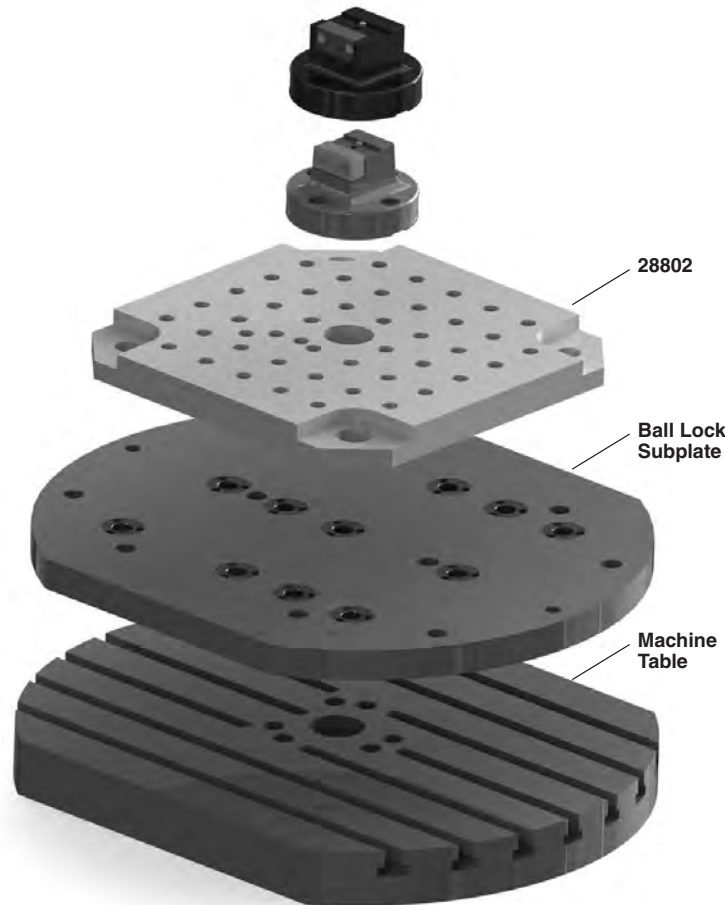

QLS Compatible Fixture Pro Tooling

QUICK CHANGE FIXTURING » BALL LOCK® MOUNTING SYSTEM

Ball Lock® T-Columns

- Class 40 Cast Iron
- Also available in Aluminum
- Ball Lock® Receiver Bushings and Liner Bushings installed
- Perpendicularity is 0.001" per foot

Custom Sizes Available with or without Ball Lock®

We are able to quote you on your special requirement with or without the Ball Lock® Mounting System. Call 1-877-426-2504 for design specification information.

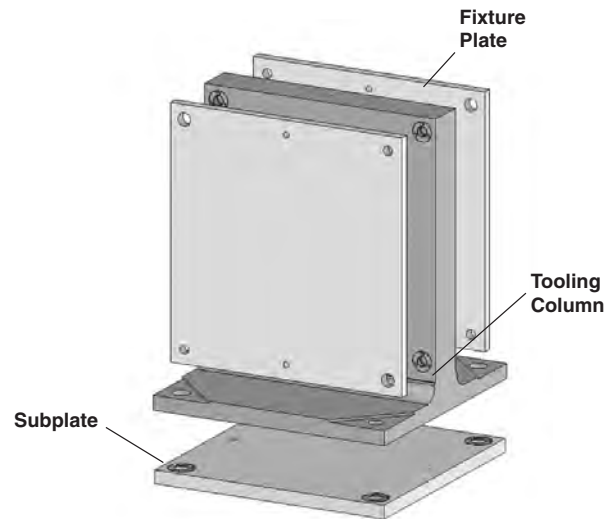

Cast Iron T-Columns With Ball Lock® Receiver Bushings Installed

See page 15 for Fixture Plates and Subplates

Pallet Size (mm)	Part Number	C (in)	D (in)	E (in)	F (in)	G (in)	H (in)	I (in)	J (in)	K (in)	L (in)	M (in)	N (in)	O (mm)	P (mm)	Wt. (lbs)
400	69101	16.375	1	15.75	15.75	14	14	14	14	4	19.875	4.875	3.5	20	20	425
400	69102	16.375	1	15.75	15.75	12	12	12	12	4	19.875	5.875	3.5	20	20	425
500	69111	22.375	1	19.68	19.68	19	17	17	17	4.7	25.875	5.375	3.5	25	25	700
500	69112	22.375	1	19.68	19.68	17	17	17	17	4.7	25.875	7.375	3.5	25	25	700
630	69121	22.375	1.5	25	25	23	22	21	21	4	29.875	5.375	3.5	35	25	1125

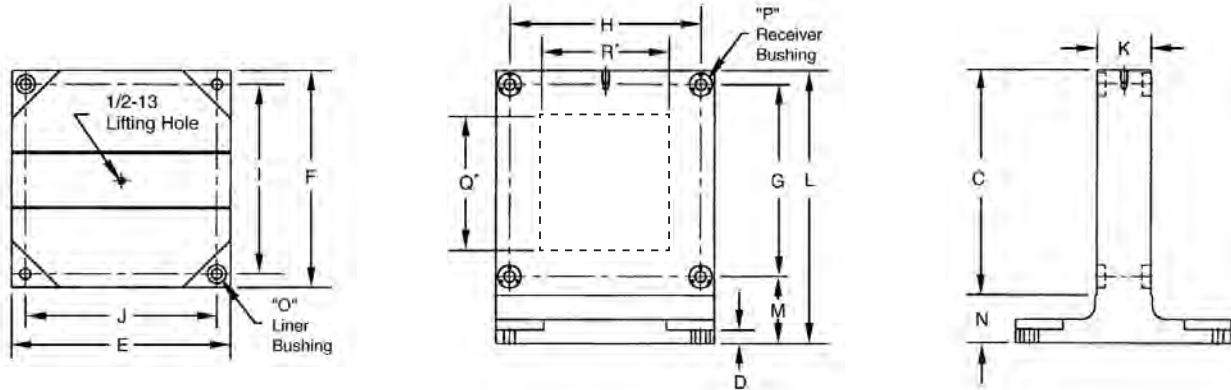

*Note: Window sections are also available on T-Columns. Specify window size and location (Q and R Dimensions).

Corresponding Fixture Plates, Subplates and Ball Lock® Shanks

Pallet Size (mm)	T-Column Part Number	Aluminum Fixture Plate Part Number	Steel Fixture Plate Part Number	Fixture Plate Size	Fixture Plate Ball Lock® Shank Part Number	Shank Size	Subplate Part Number	Subplate Ball Lock® Shank Part Number	Shank Size
400	69101	28717	28817	16 x 16	49601	20mm x 3/4	49102	49602	20mm x 1
400	69102	28715	28815	16 x 16	49601	20mm x 3/4	49101	49602	20mm x 1
500	69111	28745	28845	20 x 22	49612	25mm x 1	49103	49612	25mm x 1
500	69112	28727	28827	20 x 20	49612	25mm x 1	49103	49612	25mm x 1
630	69121	28746	28846	25 x 26	49612	25mm x 1	49104	49633	35mm x 1-1/2

Use Hoist Ring 23411, see Lifting Solutions Catalog or Master Catalog for lifting and handling – Order separately.

Engineering Changes

Product improvement is a continuing process at Jergens. Specifications and engineering data are subject to change after publishing. Contact Jergens Technical Sales Department to verify any dimensions or specifications.

Ball Lock® 4-Sided Tooling Columns

- Class 40 Cast Iron
- Also available in Aluminum
- Ball Lock® Receiver Bushings and Liners installed
- Provides accurate fixturing base for CNC machining centers
- Perpendicularity is 0.001" per foot

Custom Sizes Available with or without Ball Lock®

We are able to quote you on your special requirement with or without the Ball Lock® Mounting System. Call 1-877-426-2504 for design specification information.

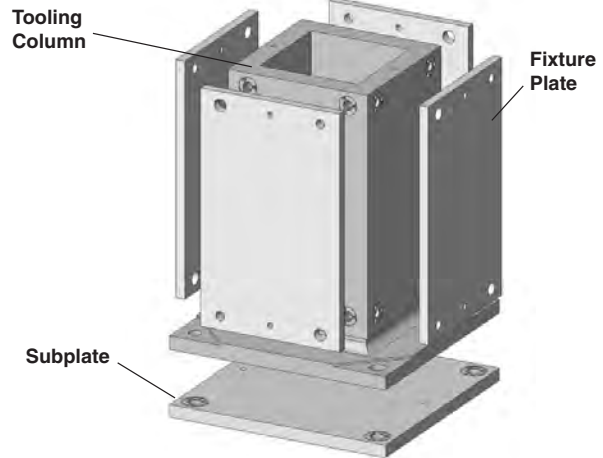

Cast Iron 4-Sided Tooling Columns With Ball Lock® Receiver Bushings Installed

See page 15 for Fixture Plates and Subplates

Pallet Size (mm)	Part Number	A (in)	B (in)	C (in)	D (in)	E (in)	F (in)	G (in)	H (in)	I (in)	J (in)	K (in)	L (in)	M (in)	N (in)	O (mm)	P (mm)	Wt. (lbs)
400	69001	10	10	20	1	16	16	18	6.75	14	14	1.75	23.875	4.875	3.875	20	20	510
500	69011	12	12	25	1	20	20	22	8	17	17	1.625	28.875	5.375	3.875	25	25	736
630	69021	16	16	26	1.5	25	25	23	11.5	21	21	2	29.875	5.375	3.875	35	25	1122

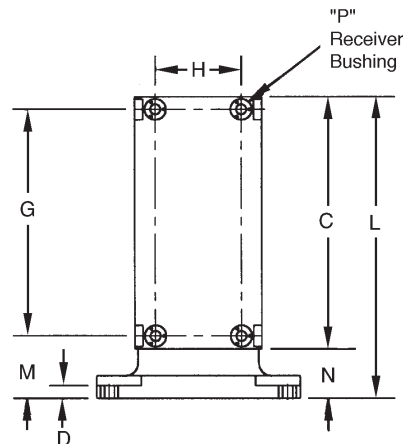
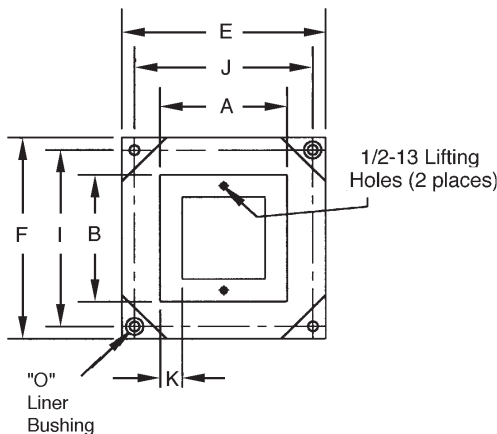

Corresponding Fixture Plates, Subplates and Ball Lock®Shanks

Pallet Size (mm)	T-Column Part Number	Aluminum Fixture Plate Part Number	Steel Fixture Plate Part Number	Fixture Plate Size	Fixture Plate Ball Lock® Shank Part Number	Shank Size	Subplate Part Number	Subplate Ball Lock® Shank Part Number	Shank Size
400	69001	28741	28841	10 x 20	49601	20mm x 3/4	49102	49602	20mm x 1
500	69011	28742	28842	12 x 25	49612	25mm x 1	49103	49612	25mm x 1
630	69021	28743	28843	16 x 26	49612	25mm x 1	49104	49633	35mm x 1-1/2

Use Hoist Ring 23411, see Lifting Solutions Catalog or Master Catalog for lifting and handling – Order separately.

Engineering Changes

Product improvement is a continuing process at Jergens. Specifications and engineering data are subject to change after publishing. Contact Jergens Technical Sales Department to verify any dimensions or specifications.

Subplates For Tooling Columns and Fixture Plates

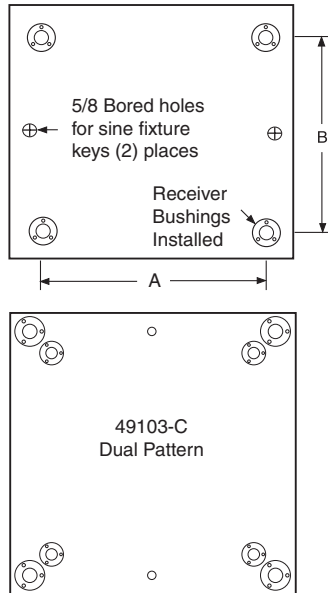

Standard Steel Subplates for Tooling Columns

Subplate Mounting holes can be provided per customer specification. Supplied with Ball Lock® Receiver Bushings installed.

Part Number	Pallet Size (mm)	For Tooling Columns	Ball Lock® Pattern		Receiver Size (mm)	Thickness of Subplate (in.) ±0.005	Wt. (lbs)
			A (in.)	B (in.)			
49102	400	69001, 69101	14	14	20	1 1/8	79
49103	500	69011, 69111	17	17	25	1 1/4	137
49103-C	500	69101, 69001	14/17	14/17	20/25	1 1/4	137
—	—	69111, 69011	Dual	Dual	Dual	1 1/4	—
49104	630	69021, 69121	21	21	35	1 3/8	240

Custom Sizes Available with or without Ball Lock®

We are able to quote you on your special requirement with or without the Ball Lock® Mounting System. Call 1-877-426-2504 for design specification information.

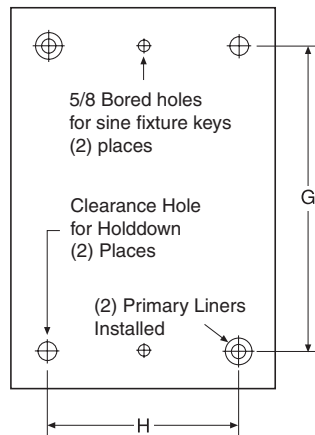

Fixture Plates for Standard Tooling Columns and T-Columns

Supplied with 2 primary Ball Lock® Liner Bushings installed.

Pallet Size (mm)	Part Number				For Tooling Columns	Type	Fixture Plate Size (in.)	Fixture Plate Thickness ±0.005"	Ball Lock® Pattern		Liner Size (mm)
	Aluminum	(lbs)	Steel	(lbs)					H (in.)	G (in.)	
400	28741	14	28841	43	69001	4-S	10x20	3/4	6.75	18	20
500	28742	28	28842	85	69011	4-S	12x25	1	8	22	25
630	28743	39	28843	118	69021	4-S	16x26	1	11.50	23	25
400	28717	18	28817	55	69101	T	16x16	3/4	14	14	20
400	28715	18	28815	55	69102	T	16x16	3/4	12	12	20
500	28745	41	28845	125	69111	T	20x22	1	17	19	25
500	28727	38	28827	114	69112	T	20x20	1	17	17	25
630	28746	61	28846	184	69121	T	25x26	1	22	23	25

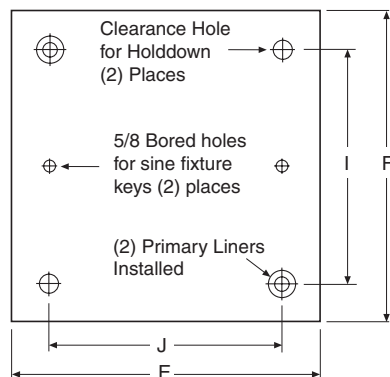

Fixture Plates for Tooling Column Subplates

Supplied with 2 primary Ball Lock® Liner Bushings installed.

Pallet Size (mm)	Part Number				For Subplate	Plate Dim.		Fixture Plate Thickness ±0.005"	Ball Lock® Pattern		Liner Size (mm)
	Aluminum	(lbs)	Steel	(lbs)		E (in.)	F (in.)		I (in.)	J (in.)	
400	28717	18	28817	55	49102	16	16	3/4	14	14	20
500	28727	38	28827	114	49103	20	20	1	17	17	25
630	28732	58	28832	177	49104	25	25	1	21	21	35

Ball Lock® For 4th Axis Rotary Indexers

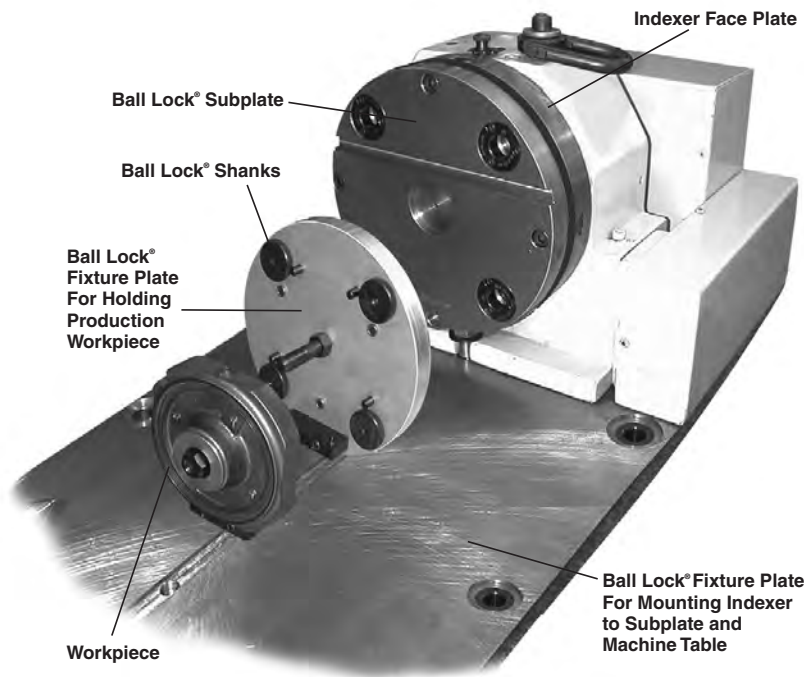

Problem:

Rotary indexers increase the versatility of vertical machining centers, yet they offer one major challenge: set-up is so time-consuming that it may limit a machine's flexibility. In many cases, machinists dedicate their 4th Axis tool to a single machine to avoid the agony of an extended set-up and changeover.

Benefits:

- Maximize indexer utilization
- Eliminate lengthy set-ups
- Accurate fixture plate changeover in seconds

Jergens' Solution:

Ball Lock® Mounting System for Indexers provides a double solution.

First, Ball Lock® mounting plates free up your machine for additional work by allowing a fast and accurate installation and removal of the complete indexer. Avoid hours of set up. The Ball Lock® System does it in minutes, with repeatability at $\pm 0.0005"$ ($\pm 0.013\text{mm}$). Low profile, positive clamping, proven in over many years of field use.

Second, the Ball Lock® System provides your fixture plate changeover. By mounting the round subplate to the indexer faceplate, you'll "plug-in" new fixtures in record time (less than 60 seconds).

Subplates and fixture plates come with bushings pre-installed.

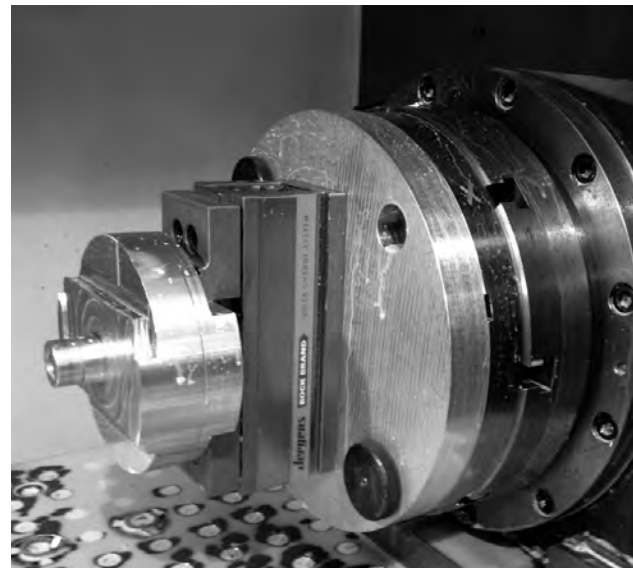
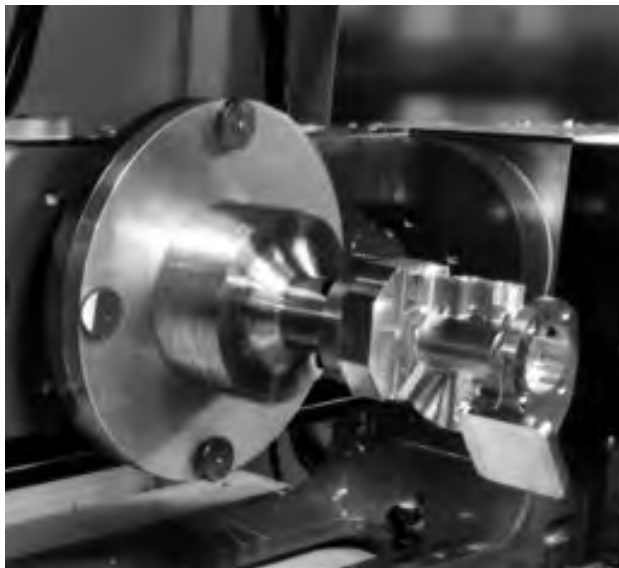

QUICK CHANGE FIXTURING » BALL LOCK® MOUNTING SYSTEM

Round Ball Lock® Fixture Plates and Subplates

Standard Round

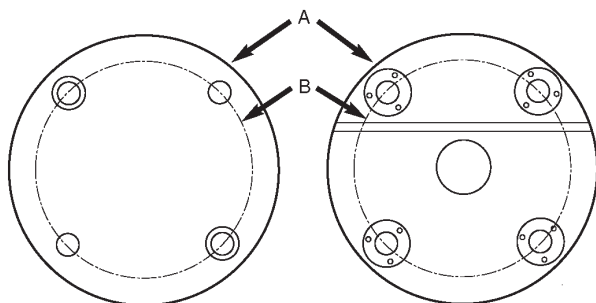

Fixture Plate

Subplate

Cast Aluminum, FreeMax™ or Steel equivalent

Fixture Plate

Part Number Alum.	Part Number Steel	A	B	Thick. ±0.005"	Ball Lock® Liner	Ball Lock® Shank	Weight (lbs) Alum.	Weight (lbs) Steel
28707	28807	8"	6"	3/4	16mm	49608	3.5	12.0
28708	28808	10"	8"	1	20mm	49602	7.0	28.0
28709	28809	12"	10"	1	20mm	49602	11	33.0
28710	28810	14"	12"	1	20mm	49602	15.0	43.0

Subplate

Part Number Alum.	A	B	Thick. ±0.005"	Ball Lock® Receiver	Center Hole	Weight (lbs)
49107	8"	6"	3/4	16mm	1.00"	11.0
49108	10"	8"	1	20mm	2.00"	21.0
49109	12"	10"	1	20mm	2.00"	33.0

Metric sizes also available; please call for information.

Custom Round Plates

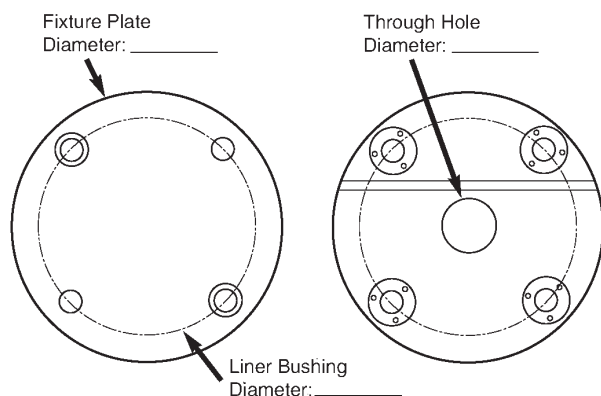

- Cast Aluminum or FreeMax™ is steel or equivalent
- Thickness ± 0.005"
- Parallel within 0.001" Steel

Indexer:

Make: _____

Model: _____

Diameter: _____

Light Duty or Heavy Duty: _____

Through Hole Bore: _____

CNC Machine:

Make: _____

Model: _____

Weight Capacity: _____

Indexer Faceplate:

T-Slot Size: _____

Configuration/Orientation: _____

or

Drilled Tapped Hole Size: _____

Configuration/Orientation: _____

Engineering Changes

Product improvement is a continuing process at Jergens. Specifications and engineering data are subject to change without notice. If current information is critical to your design, it is suggested that you contact Jergens Technical Sales Department to verify any dimensions or specifications.

Locating and Clamping Shanks



- Material: Shank/Bushing, 4340 Liner, 52100
- Finish: Black Oxide
- Heat Treat: Shanks, RC 40-45 Bushings, RC 50-54 Liners, RC 62-64
- Operating Temperature Range -20° to 400°F, -30° to 200°C

Stainless Steel available.
See Page 20-21

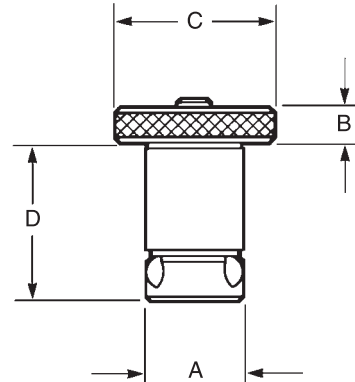

Ball Lock® Repair Kits



- Each Kit Includes:
- Replacement Screw
 - Locking Balls
 - Drive Ball
 - O-Ring

Any Ball Lock® application requires at least two sets of shanks, receiver bushings and liners. The liners are placed into the fixture plate to insure extremely accurate positioning. If more than two shanks are required (to provide additional hold down force), omit the liner bushing so that these additional holes will not interfere with your primary locating holes.

See page 23 for Fast Acting Shanks.

Locating and Clamping Shank Dimensions

Shank Diameter (mm) A	Fixture Plate Thickness ±0.005	Shank Part Number	Head of Shank		Length Under Head D	Hex Wrench Size for Set Screw	Maximum		Recommended		Shank Repair Kit Part Number
			Height B	Diameter C			Screw Torque (Ft/lb)	Hold-Down Force (lbs)	Screw Torque (Ft/lb)	Hold-Down Force (lbs)	
13	0.50	49605	0.25	0.87	1.08	3/32	1.2	750	1	625	49905
—	0.75	49606	—	—	1.33	—	—	—	—	—	49906
—	1.25	49604	—	—	1.83	—	—	—	—	—	49904
16	0.50	49607	0.32	1.50	1.15	1/8	3	1200	2	800	49907
—	0.75	49608	—	—	1.4	—	—	—	—	—	49908
—	1.25	49609	—	—	1.90	—	—	—	—	—	49909
20	0.75	49601	0.38	1.75	1.53	1/8	4	3000	3	2250	49901
—	1.00	49602	—	—	1.78	—	—	—	—	—	49902
—	1.50	49603	—	—	2.28	—	—	—	—	—	49903
25	0.75	49611	0.38	2.00	1.70	5/32	9	7000	7	5444	49911
—	1.00	49612	—	—	1.95	—	—	—	—	—	49912
—	1.50	49613	—	—	2.45	—	—	—	—	—	49913
30	0.75	49621	0.50	2.25	1.88	3/16	15	10000	12	8000	49921
—	1.00	49622	—	—	2.13	—	—	—	—	—	49922
35	0.75	49631	0.50	2.25	1.97	1/4	25	15500	19	11780	49931
—	1.00	49632	—	—	2.22	—	—	—	—	—	49932
—	1.50	49633	—	—	2.72	—	—	—	—	—	49933
—	2.00	49634	—	—	3.22	—	—	—	—	—	49934
50	0.75	49641	0.75	3.00	2.45	3/8	50	20000	38	15200	49941
—	1.00	49642	—	—	2.70	—	—	—	—	—	49942
—	1.50	49643	—	—	3.20	—	—	—	—	—	49943
—	2.00	49644	—	—	3.70	—	—	—	—	—	49944

Receiver Bushings



Face Mount

Back Mount

Two styles of receiver bushings are available. Generally, the face mount receiver bushing is utilized in blind hole applications (Slip Fit). The back mount receiver bushing is used in through hole applications (Light Press Fit).

Note: Installed bushings should be approximately .012" below subplate surface.

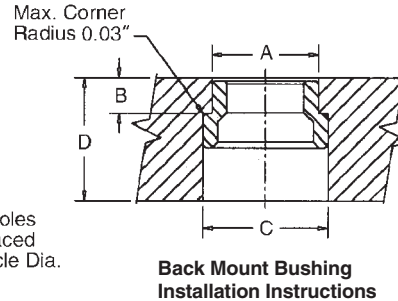
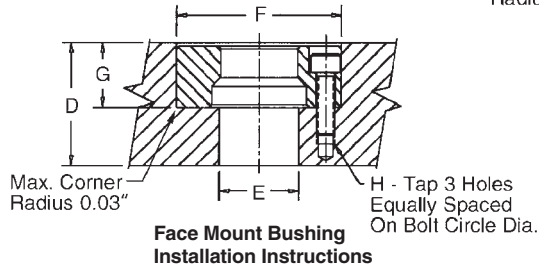
See reference below for installation of back mount style bushings.



Installation Dimensions

Face Mount

Shank Dia. (mm)	Face Mount Part Number	Actual O.D. +0.0000 -0.0004	Clearance Drill Diameter E	Bore +0.0005 -0.0000 F	Depth +0.002 -0.000 G	Tap Size & Depth ¹ H	Bolt Circle Diameter 3 PL Equally Space	Min. Subplate Thickness D
13	49506	1.3750	11/16	1.3750	0.469	8-32x5/16	0.984	3/4
16	49507	1.4370	13/16	1.4370	0.469	8-32x5/16	1.125	3/4
20	49501	1.6873	13/16	1.6873	0.637	10-32x3/8	1.362	1
25	49502	2.0623	1	2.0623	0.799	1/4-28x1/2	1.644	1-1/4
30	49503	2.2654	1 3/16	2.2654	0.871	1/4-28x3/4	1.876	1-3/8
35	49504	2.6873	1 9/16	2.6873	0.904	5/16-24x7/8	2.178	1-1/2
50	49505	3.4998	2 5/32	3.4998	1.239	3/8-24x1	2.916	2

¹Cap Screws Supplied with Face Mount Bushings.

Back Mount

Shank Dia. (mm)	Back Mount Part Number	Actual O.D. +0.0000 -0.0004 A	Depth +0.000 -0.002 B	C-Bore ±0.006 C	Min. Subplate Thickness D
13	49516	0.7870	.277	1.000	3/4
16	49517	0.8760	.285	1.155	3/4
20	49511	1.0950	.345	1.280	7/8
25	49512	1.3763	.416	1.593	1
30	49513	1.6264	.432	1.906	1-1/4
35	49514	1.8764	.493	2.155	1-5/16
50	49515	2.6269	.621	2.988	1-3/4

Liner Bushings for Fixture Plates



Locating repeatability will determine if one primary and one secondary or two primary liners are needed. With two primary liners, repeatability of ±0.0005" can be maintained if the two holes for receiver bushings are held to a centerline distance of ±0.0002" tolerance.

Note on Installation of Press Fit Liners & Back Mount Style Receiver Bushings:

To alleviate the possibility of binding the shank in the bore, the maximum interference fit between bore and bushing O.D. should not exceed .0005".

Liner Dimensions

Fixture Plate Thickness ±0.005	Shank Diameter (mm)	Primary Liner Part Number	Secondary Liner Part Number	Liner O.D. +0.0000 -0.0004
0.50	13	49705	49805	0.7518
0.75	13	49706	49806	0.7518
0.50	16	49707	49807	1.0018
0.75	16	49708	49808	1.0018
0.75	20	49701	49801	1.3772
1.00	20	49702	49802	1.3772
0.75	25	49711	49811	1.3772
1.00	25	49712	49812	1.3772
0.75	30	49721	49821	1.7523

Fixture Plate Thickness ±0.005	Shank Diameter (mm)	Primary Liner Part Number	Secondary Liner Part Number	Liner O.D. +0.0000 -0.0004
1.00	30	49722	49822	1.7523
0.75	35	49731	49831	1.7523
1.00	35	49732	49832	1.7523
1.50	35	49733	49833	1.7523
2.00	35	49734	49834	1.7523
0.75	50	49741	49841	2.5025
1.00	50	49742	49842	2.5025
1.50	50	49743	49843	2.5025
2.00	50	49744	49844	2.5025

Stainless Steel Locating and Clamping Shanks



- Material: 17-4 PH Stainless Steel
- Heat Treat: Rc 40-45

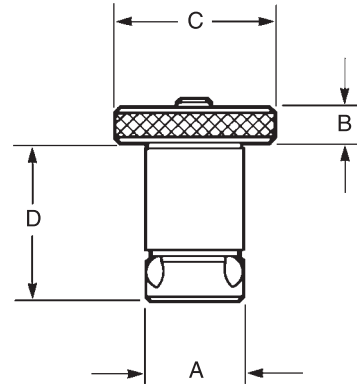

Ball Lock® Repair Kits



- Each Kit Includes:
- Replacement Screw
 - Locking Balls
 - Drive Ball
 - O-Ring

Any Ball Lock® application requires at least two sets of shanks, receiver bushings and liners. The liners are placed into the fixture plate to insure extremely accurate positioning. If more than two shanks are required (to provide additional hold down force), omit the liner bushing so that these additional holes will not interfere with your primary locating holes.

Stainless Steel Locating and Clamping Shank Dimensions

Shank Diameter (mm) A	Fixture Plate Thickness ±0.005	Shank Part Number	Head of Shank		Length Under Head D	Hex Wrench Size for Set Screw	Maximum		Recommended		Shank Repair Kit Part Number
			Height B	Diameter C			Screw Torque (Ft/lb)	Hold-Down Force (lbs)	Screw Torque (Ft/lb)	Hold-Down Force (lbs)	
13	0.50	49605SS	0.25	0.87	1.08	3/32	1.2	750	1	625	49905SS
—	0.75	49606SS	—	—	1.33	—	—	—	—	—	49906SS
16	0.50	49607SS	0.32	1.50	1.15	1/8	3	1200	2	800	49907SS
—	0.75	49608SS	—	—	1.4	—	—	—	—	—	49908SS
20	0.75	49601SS	0.38	1.75	1.53	1/8	4	3000	3	2250	49901SS
—	1.00	49602SS	—	—	1.78	—	—	—	—	—	49902SS
25	0.75	49611SS	0.38	2.00	1.70	5/32	9	7000	7	5444	49911SS
—	1.00	49612SS	—	—	1.95	—	—	—	—	—	49912SS
30	0.75	49621SS	0.50	2.25	1.88	3/16	15	10000	12	8000	49921SS
—	1.00	49622SS	—	—	2.13	—	—	—	—	—	49922SS
35	0.75	49631SS	0.50	2.25	1.97	1/4	25	15500	19	11780	49931SS
—	1.00	49632SS	—	—	2.22	—	—	—	—	—	49932SS
—	1.50	49633SS	—	—	2.72	—	—	—	—	—	49933SS
—	2.00	49634SS	—	—	3.22	—	—	—	—	—	49934SS
50	0.75	49641SS	0.75	3.00	2.45	3/8	50	20000	38	15200	49941SS
—	1.00	49642SS	—	—	2.70	—	—	—	—	—	49942SS
—	1.50	49643SS	—	—	3.20	—	—	—	—	—	49943SS
—	2.00	49644SS	—	—	3.70	—	—	—	—	—	49944SS

QUICK CHANGE FIXTURING » BALL LOCK® MOUNTING SYSTEM

Stainless Steel Receiver Bushings



Face Mount

Back Mount

Two styles of receiver bushings are available. Generally, the face mount receiver bushing is utilized in blind hole applications (Slip Fit). The back mount receiver bushing is used in through hole applications (Light Press Fit).

Note: Installed bushings should be approximately .012" below subplate surface.

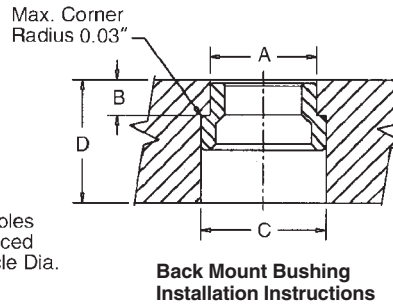
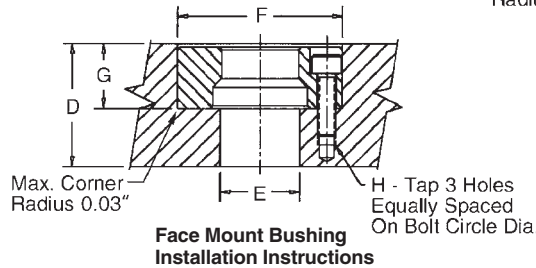
See reference below for installation of back mount style bushings.



Installation Dimensions

Face Mount

Shank Dia. (mm)	Face Mount Part Number	Actual O.D. +0.0000 -0.0004	Clearance Drill Diameter E	Bore +0.0005 -0.0000 F	Depth +0.002 -0.000 G	Tap Size & Depth ¹ H	Bolt Circle Diameter 3 PL Equally Space	Min. Subplate Thickness D
13	49506SS	1.3750	11/16	1.3750	0.469	8-32x5/16	0.984	3/4
16	49507SS	1.4370	13/16	1.4370	0.469	8-32x5/16	1.125	3/4
20	49501SS	1.6873	13/16	1.6873	0.637	10-32x3/8	1.362	1
25	49502SS	2.0623	1	2.0623	0.799	1/4-28x1/2	1.644	1-1/4
30	49503SS	2.2654	1 3/16	2.2654	0.871	1/4-28x3/4	1.876	1-3/8
35	49504SS	2.6873	1 9/16	2.6873	0.904	5/16-24x7/8	2.178	1-1/2
50	49505SS	3.4998	2 5/32	3.4998	1.239	3/8-24x1	2.916	2

¹Cap Screws Supplied with Face Mount Bushings.

Back Mount

Shank Dia. (mm)	Back Mount Part Number	Actual O.D. +0.0000 -0.0004 A	Depth +0.000 -0.002 B	C-Bore ±0.006 C	Min. Subplate Thickness D
13	49516SS	0.7870	.277	1.000	3/4
16	49517SS	0.8760	.285	1.155	3/4
20	49511SS	1.0950	.345	1.280	7/8
25	49512SS	1.3763	.416	1.593	1
30	49513SS	1.6264	.432	1.906	1-1/4
35	49514SS	1.8764	.493	2.155	1-5/16
50	49515SS	2.6269	.621	2.988	1-3/4

Stainless Steel Liner Bushings for Fixture Plates



Locating repeatability will determine if one primary and one secondary or two primary liners are needed. With two primary liners, repeatability of ±0.0005" can be maintained if the two holes for receiver bushings are held to a centerline distance of ±0.0002" tolerance.

Note on Installation of Press Fit Liners & Back Mount Style Receiver Bushings:

To alleviate the possibility of binding the shank in the bore, the maximum interference fit between bore and bushing O.D. should not exceed .0005".

Liner Dimensions

Fixture Plate Thickness ±0.005	Shank Diameter (mm)	Primary Liner Part Number	Secondary Liner Part Number	Liner O.D. +0.0000 -0.0004	Fixture Plate Thickness ±0.005	Shank Diameter (mm)	Primary Liner Part Number	Secondary Liner Part Number	Liner O.D. +0.0000 -0.0004
.50	13	49705SS	49805SS	0.7518	1.00	30	49722SS	49822SS	1.7523
.75	13	49706SS	49806SS	0.7518	.75	35	49731SS	49831SS	1.7523
.50	16	49707SS	49807SS	1.0018	1.00	35	49732SS	49832SS	1.7523
.75	16	49708SS	49808SS	1.0018	1.50	35	49733SS	49833SS	1.7523
.75	20	49701SS	49801SS	1.3772	2.00	35	49734SS	49834SS	1.7523
1.00	20	49702SS	49802SS	1.3772	.75	50	49741SS	49841SS	2.5025
.75	25	49711SS	49811SS	1.3772	1.00	50	49742SS	49842SS	2.5025
1.00	25	49712SS	49812SS	1.3772	1.50	50	49743SS	49843SS	2.5025
.75	30	49721SS	49821SS	1.7523	2.00	50	49744SS	49844SS	2.5025

Ball-Lock Fixture Plate Machining Kits



Jergens fixture plate machining kits consist of extra-long Ball-Lock shanks and spacers. These kits allow a fixture plate to be installed on a subplate with clearance between the plates. When a user is initially building a fixture on a Ball-Lock Fixture plate, this clearance allows cutting tools to break thru the fixture plate without damaging the subplate below. The advantage of this setup is fixture plates can be machined while mounted to the same subplates they will used with in production. Kits include (4) shanks and (4) spacers.

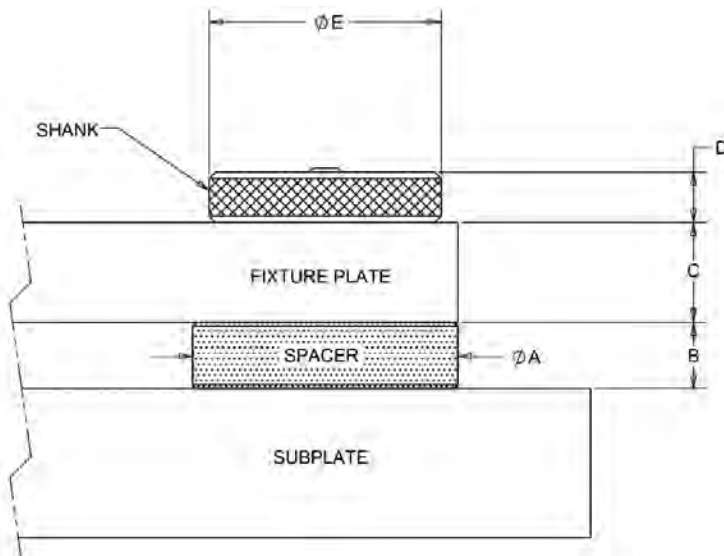

Kit Part Number	Shank Dia.	Spacer Dia. A	Spacer Thk. B	Fixture Plate Thk. C	Shank Head Thk. D	Shank Head Dia. E	Shank Part Number	Spacer Part Number
49244	13mm	1.625	0.50	0.75	0.25	0.87	49604	49584
49249	16mm	1.75	0.50	0.75	0.32	1.50	49609	49589
49242	20mm	2.00	0.50	1.00	0.38	1.75	49603	49582
49243	20mm	2.00	0.75	0.75	0.38	1.75	49603	49583
49253	25mm	2.375	0.50	1.00	0.38	2.00	49613	49593

QUICK CHANGE FIXTURING » BALL LOCK® MOUNTING SYSTEM

Accessories

Tapered Caps and Plugs

Keep debris out of your subplate's receiver bushings when not in use. Polyethylene caps snap in and out easily.



Packaged
10 per
pack.

Receiver Bushing Diameter	Part Number
13	49201
16	49202
20	49203
25	49204
30	49205
35	49206
50	49207



Lifting Handles

For easy handling of fixture plates up to 500 lbs.

Part Number	Length	Ht.	W	Mounting Distance
33701	4.21	1.42	0.83	3.68

Multi-Slot Sine Fixture Keys



Locate subplates or fixture plates to slotted machine tables without having to slot the plate. Available in inch sizes from 1/2" to 7/8" slots, and in metric sizes from 14mm to 22mm slots.
NOTE: See page 238 for dimensions.

Part Number	Shank Size A	Key Width			Wt. (lbs)	Recommended Hole Dia.
		B	C	D		
39520	0.625	0.4995	0.8745	—	0.09	0.625 Shank Size 0.6255 +/-0.0005
39521	0.625	0.562	0.7495	—	0.09	0.625 Shank Size 0.6255 +/-0.0005
39522	0.625	0.6245	0.687	0.812	0.09	0.625 Shank Size 0.6255 +/-0.0005
39523	0.75	0.9995	1.062	—	0.19	0.750 Shank Size 0.7505 +/-0.0005

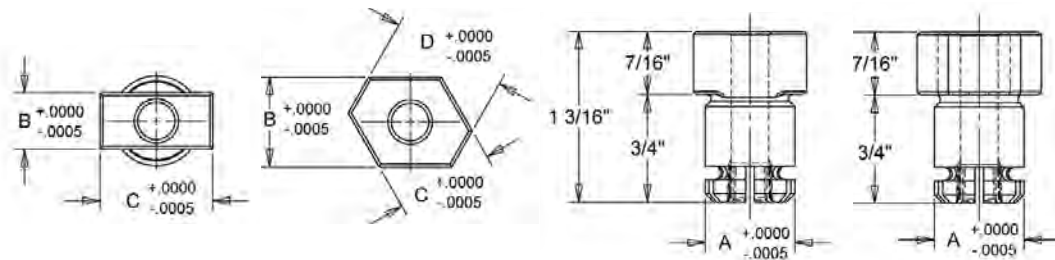

Fast Acting Ball Lock® Shanks

Ball Lock® Shank Diameter (mm)	Fixture Plate Thickness (in.)	Fast Acting			
		Jergens Ball Lock® Shank w/Jergens Thumb Screw		Jergens Ball Lock® Shank Adjustable Handle	
		Part Number		Part Number	
		Assembly	T-Screw	Assembly	Handle
13	1/2	49605-S	43900	N/A	—
—	3/4	49606-S	43900	N/A	—
16	1/2	49607-S	43904	49607-H	34314
—	3/4	49608-S	43904	49608-H	34315
20	3/4	49601-S	43904	49601-H	34315
—	1	49602-S	43905	49602-H	34316
25	3/4	49611-S	43907	49611-H	34328
—	1	49612-S	43908	49612-H	34329
30	3/4	49621-S	43910	49621-H	34334
—	1	49622-S	43911	49622-H	34335
35	3/4	49631-S	43913	49631-H	34339
—	1	49632-S	43913	49632-H	34339
—	1-1/2	49633-S	43914	N/A	—
—	2	49634-S	43914	N/A	—



- Fast acting thumb screws 2 1/2 turns. No tools needed.

Thumb Screw



- Handle can be moved out of the work area to avoid interference.

Adjustable Handle

Receiver Bushing Plugs



- Material: Aluminum
- Finish: Blue Anodize
- O-Ring Included
- Prevent chips and coolant from accumulating inside receiver bushings that are not in use
- Eliminates the need to clean out receiver bushings in between setups
- Flush mount design does not protrude above subplate surface
- Durable aluminum construction provides better resistance to hot chips than comparable plastic plugs
- Tapped hole for easy removal

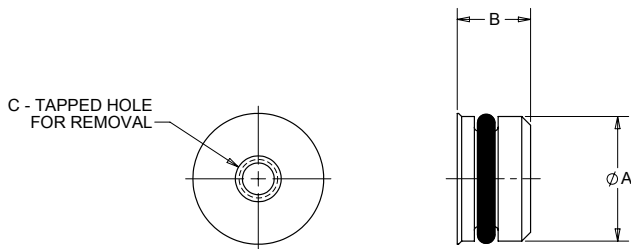

Bushing Dia. (mm)	Plug Part Number	A (mm)	B (mm)	C	Extraction Tool Part No.
13	49231	13	8	M4 x 0.7	49208
16	49232	16	8	M4 x 0.7	49208
20	49233	20	8	M4 x 0.7	49208
25	49234	25	10	M4 x 0.7	49208
30	49235	30	11	M4 x 0.7	49208
35	49236	35	14	M6 x 1.0	49209
50	49237	50	17	M6 x 1.0	49209



QUICK CHANGE FIXTURING » BALL LOCK® MOUNTING SYSTEM

Quick Change Kits

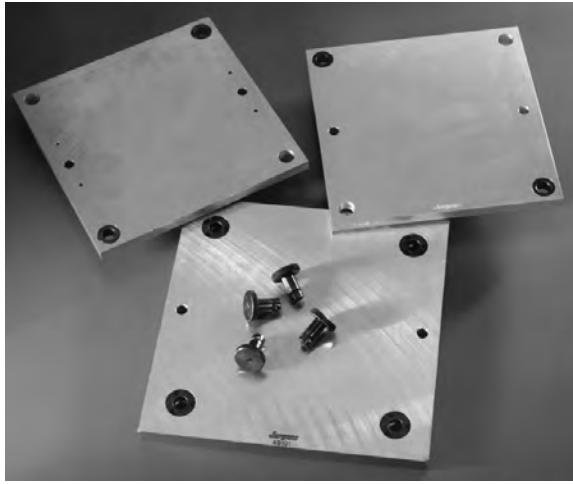

The Jergens Ball Lock® Quick Change Kits speed fixture changeover in all types of manufacturing operations. Each kit includes two aluminum fixture plates with two primary liner bushings installed; one steel subplate with receiver bushings installed, and four 20mm Ball Lock® shanks with working loads of 3000 lbs. each. While one fixture plate is on the machine, the operator can load parts on the other. This minimizes downtime for true set-up reduction. To enable the subplate to be mounted on a slotted table without the need to indicate the subplate, sine fixture keys can be used. The sine fixture key bored holes are oriented parallel to the receiver bushings on the subplate and to the liner bushings on the fixture plate. These also allow the fixture plate to be mounted on a toolroom mill without the need to indicate it. This is extremely useful when machining location points on your fixture.



Everything You Need to Change Fixtures in Less Than One Minute

Aluminum Fixture Plate

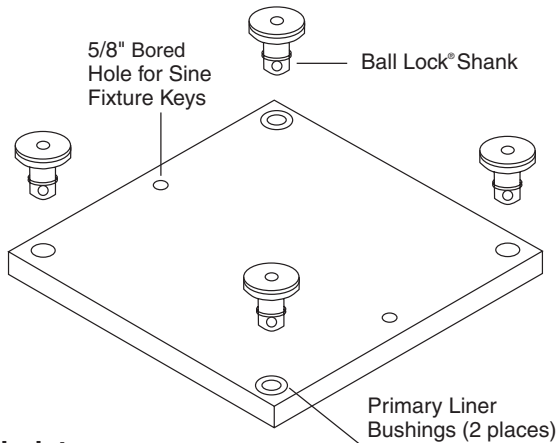

Steel Subplate

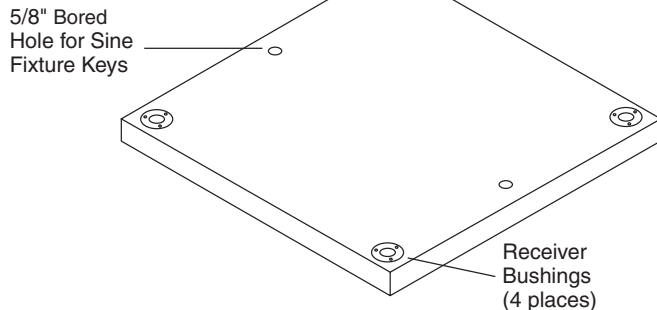

Quick Change Kits

Part Number	Kit Includes
49001	2 - 28713 (14"x14"x3/4") aluminum fixture plates with 20mm liner bushings installed 1 - 49101 (16"x16"x1-1/8") steel subplate with receiver bushings installed 4 - 49601 (20mm) Ball Lock® Shanks
49002	2 - 28715 (16"x16"x3/4") aluminum fixture plates with 20mm liner bushings installed 1 - 49101 (16"x16"x1-1/8") steel subplate with receiver bushings installed 4 - 49601 (20mm) Ball Lock® Shanks
49004	Bridgeport™-Style 2 - 28731 (10"x15"x3/4") aluminum fixture plates with 16mm liner bushings installed 1 - 49121 (10"x15"x3/4") steel subplate with receiver bushings installed 4 - 49608 (16mm) Ball Lock® Shanks

Ball Lock® Selector Guides for Popular Machine Tools

Use these guides to quickly select the correct Ball Lock® Mounting System for your Machine Tool.

To view our Ball Lock® Selector Guides visit our website at www.jergensinc.com/showcase-balllock-selector-guides

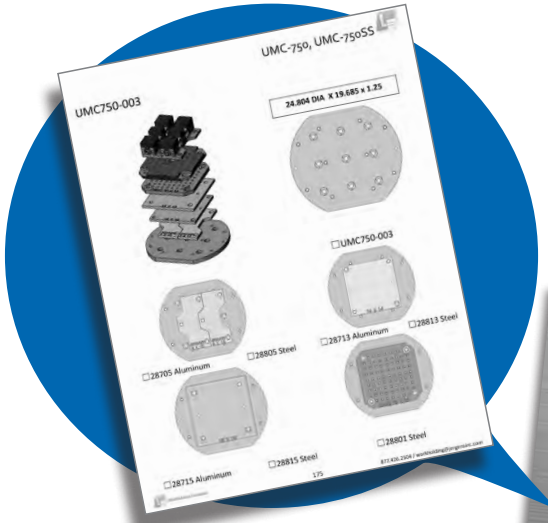

QUICK CHANGE FIXTURING » BALL LOCK® MOUNTING SYSTEM

We Put It All Together... In Seconds.

Jergens
BALL LOCK
MOUNTING SYSTEM
METRIC

Maximize productivity levels and dramatically increase throughput with Ball Lock®.

Looking to realize the full benefits of lean manufacturing? Then you need the one system that puts it all together, so you can put it all together...and that's Ball Lock®.

Ball Lock® is the industry's most popular quick-change, fixturing-flexible mounting system that can be configured to create lean-optimized solutions for your most demanding needs.

The original quick change system for fast set-ups and machine changeover.



SHANKS



RECEIVERS



FIXTURE PLATES & SUBPLATES



VICES



The Ball Lock® Mounting System is used as a Quick Change Solution on the following:

- CNC Machines
- Palletized Fixtures
- Stamping
- Fabricating
- Injection Molding
- Packaging Machines
- Assembly Machines
- EDM
- Robotics
- Welding Fixtures

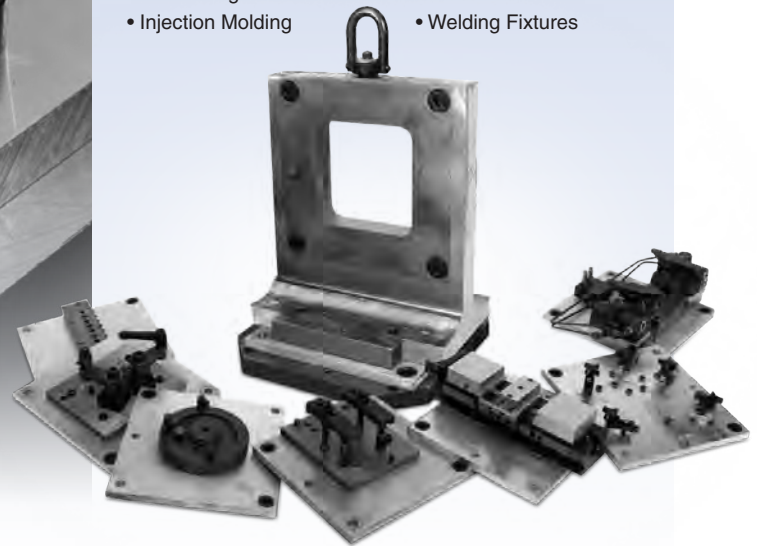

Pre-Machined Ball Lock® Steel Subplate

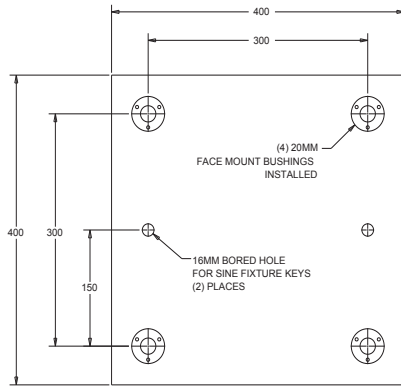

400 x400 Subplate

Part Number	Wt. (kg)
59101	37

Equipped with four 20mm receiver bushings for use with 350x350 or 400x400 (mm) fixture plates. Ideal for horizontal machining centers or multiple pallet machining centers.

- FreMax™ 15 steel plate or equivalent
- Thickness: 28.57mm ±0.13mm
- Parallel within 0.025mm

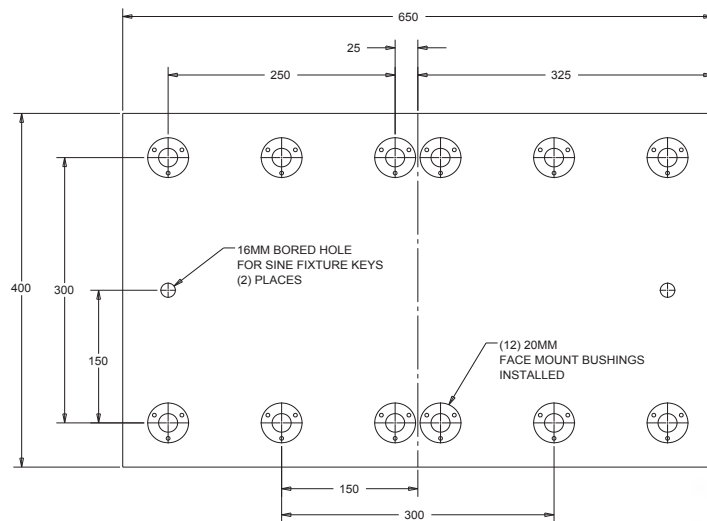

650x400 Dual Station Subplate

Part Number	Wt. (kg)
59111	58

Equipped with twelve installed 20mm receiver bushings to easily locate and mount Jergens Standard Fixture Plates.

- Ideal for vertical machining centers
- Thickness: 28.57mm ±0.13mm
- Parallel within 0.025mm

Aluminum Plate Part Number	Steel Plate Part Number	Number of Fixture Plates	Plate Width and Length (mm)
58713	58813	1	350x350
58715	58815	1	400x400
58711	58811	2	300x350

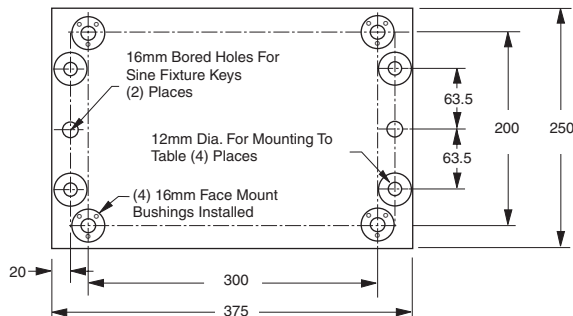
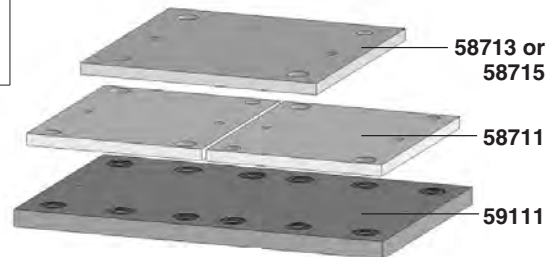

250x375 Bridgeport™ - Style Subplate

Part Number	Wt. (kg)
59121	15

Equipped with four installed 16mm receiver bushings and 12mm mounting holes. Used with the Bridgeport™ style fixture plates 58731 or 58831.

- Thickness: 19.05mm ±0.13mm
- Parallel within 0.025mm

Ball Lock® Quick Change Kits include all components needed in a single package. See page 43 for details.

Multi-Purpose Subplates

1000x500 Multi-Purpose Subplate

Part Number	Wt. (kg)
59112	130

The Jergens Multi-Purpose Subplate accommodates a wide variety of fixture plates and vises. This versatility facilitates using the same VMC for diverse products in repetitive runs-long and short batch sizes.

- FreMax™ 15 Steel or Equivalent
- Thickness: 31.75mm ±0.13mm
- Parallel within 0.025mm

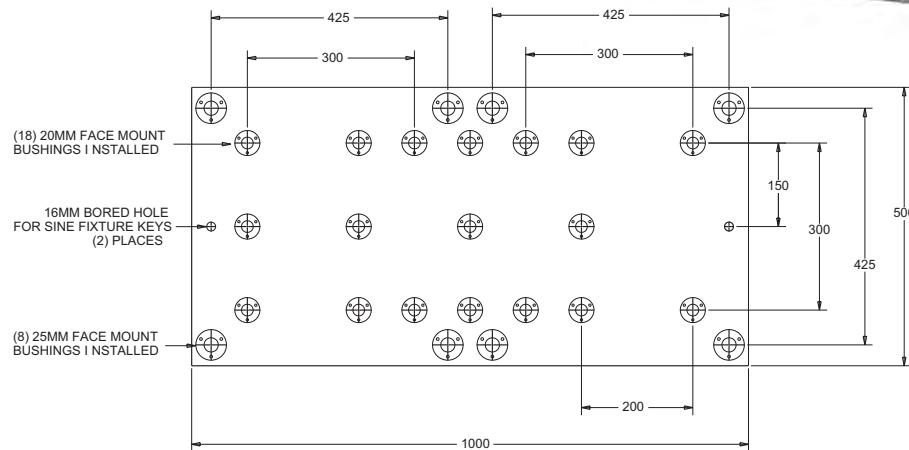
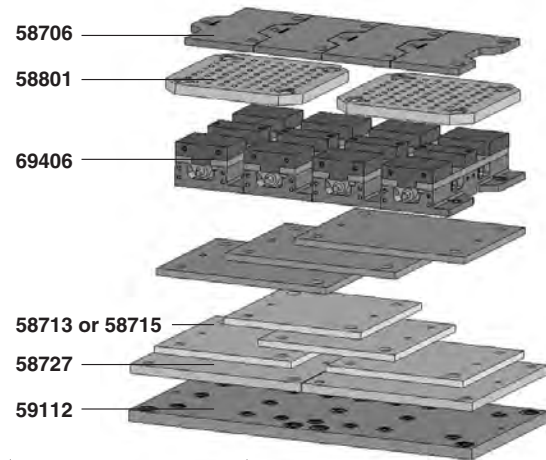

Fixture Plate Options for Multi-Purpose Subplates – Aluminum or Steel

Fixture Plate*/Vise Part Number	Thickness of Fixture Plate	Number of Fixture Plates/Vise That Mount on Multi-Purpose Subplate	Receiver Bushing Center Distance	Receiver Bushing Size	Required Ball Lock® Shank Part Number	Number of Shanks Required Per Fixture Plate/Vise
58713 (350 x 350) Fixture Plate	20mm	2	300 x 300	20 mm	49651	4
58715 (400 x 400) Fixture Plate	20mm	2	300 x 300	20 mm	49651	4
58801 (400 x 400) Modular Grid Plate	30mm**	2	300 x 300	20 mm	49652	4
58706 Jigsaw Interlocking Plate	20mm	4	300 x 200	20 mm	49651	3
58727 (500 x 500) Fixture Plate	25mm	2	425 x 425	25 mm	49662	4
69406 150mm Jigsaw Vise	20mm	4	300 x 200	20 mm	49651	3

* See next page for dimensional data on fixture plates. Part numbers shown for aluminum plates, also available in steel.

** Counterbored to 25mm at mounting holes.

Fixture Plates for Use on Multi-Purpose Subplate

350x350x20mm Fixture Plate

Aluminum Plate Part Number	Wt (lbs)	Steel Plate Part Number	Wt (lbs)
58713	6	58813	19

400x400 Fixture Plate

Aluminum Plate Part Number	Wt (lbs)	Steel Plate Part Number	Wt (lbs)
58715	8	58815	25

- Cast Aluminum or FreMax™ 15 Steel or equivalent
- Thickness: 20mm ±0.13mm
- Parallel within 0.025mm Steel
- Mounts to subplates with Ball Lock® Shank 49651 (20x20mm)

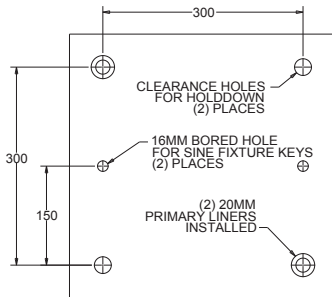

400x400 Modular Grid Fixture Plate

Aluminum Plate Part Number	Wt (lbs)
58801	38

- FreMax™ 15 Steel or equivalent
- Thickness: 28.57mm ±0.13mm
- Parallel within 0.025mm Steel

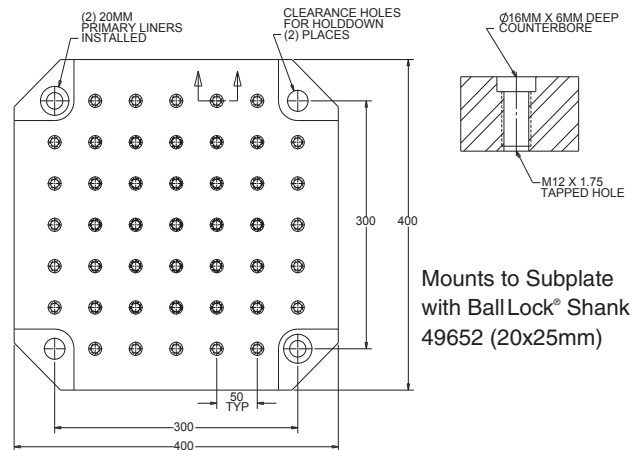

Mounts to Subplate with Ball Lock® Shank 49652 (20x25mm)

Jigsaw Interlocking Fixture Plate

Aluminum Plate Part Number	Wt (lbs)	Steel Plate Part Number	Wt (lbs)
58706	4	58806	12

- Material: Cast Aluminum or FreMax™ 15 Steel or equivalent
- Thickness: 20mm ±0.13mm
- Parallel within 0.025mm Steel
- For use with narrow base 100mm or 150mm vise models
- Design allows close spacing of vises for more parts per run
- Mounts to Subplates using Ball Lock® Shank 49651 (20x20mm)
- Useful for high density fixturing

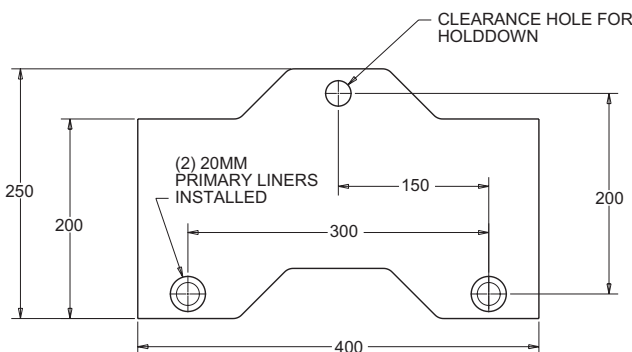

500x500x25mm Fixture Plate

Aluminum Plate Part Number	Wt (lbs)	Steel Plate Part Number	Wt (lbs)
58727	17	58827	48

- Cast Aluminum or FreMax™ 15 Steel or equivalent
- Thickness: 25mm ±0.13mm
- Parallel within 0.025mm Steel
- Mounts to Subplates using Ball Lock® Shank 49662 (25x25mm)

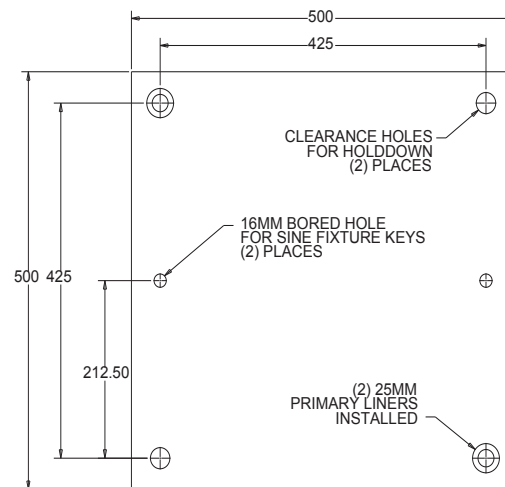

Ball Lock® Fixture Plates

- Cast Aluminum; or FreMax™ 15 Steel or equivalent
- Thickness $\pm 0.13\text{mm}$
- Parallel within $.025\text{mm}$ Steel
- 6061–T-651 plates, flat within 0.03mm available upon request

Ball Lock® Fixture Plates with 2 Primary Liners Installed

Part Number				Plate Dimensions (mm)	Plate Thickness $\pm 0.13(\text{mm})$	Ball Lock® Shank Size (mm)	Ball Lock® Shank Part Number
Aluminum	Weight (Kgs)	Steel	Weight (Kgs)				
58706	4	58806	12	250 x 400	20	20	49651
58711	5	58811	16	300 x 350	20	20	49651
58713	6	58813	19	350 x 350	20	20	49651
58715	8	58815	25	400 x 400	20	20	49651
58727	17	58827	48	500 x 500	25	25	49662
—	—	58801	38	400 x 400	28.57	20	49652
58731	5	58831	15	375 x 250	20	16	49657

- Machined to close tolerances
- Repeatability $\pm 0.013\text{mm}$ or better
- Reduces fixture set-up and assembly time
- Provided with 16mm bored holes for sine fixture keys
- For horizontal or vertical machining centers, Tool Room Mills machines, or multiple pallet machining centers

Custom Sizes Available

Jergens will make Ball Lock® fixture plates or subplates to your specifications. Call 1-877-426-2504 for further information.

375x250x20mm Fixture Plate Bridgeport™ Style

Aluminum Plate Part Number	Wt. (kg)	Steel Plate Part Number	Wt. (kg)
58731	5	58831	15

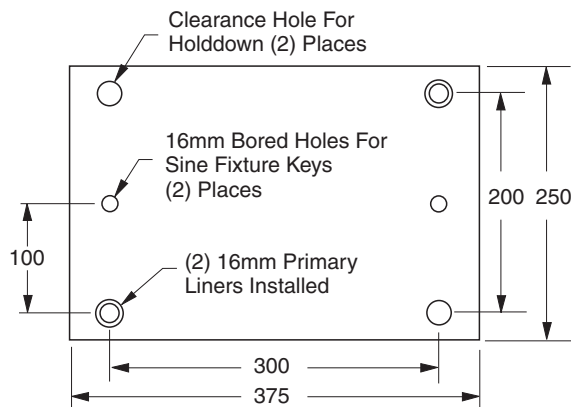

300x350x20mm Fixture Plate

Aluminum Plate Part Number	Wt. (kg)	Steel Plate Part Number	Wt. (kg)
58711	5	58811	16

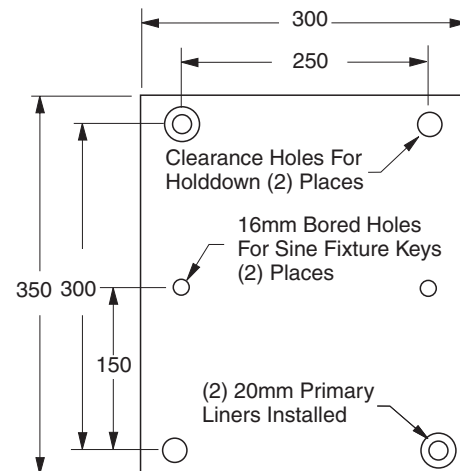

METRIC

METRIC

QUICK CHANGE FIXTURING » BALL LOCK® MOUNTING SYSTEM

Pre-Machined Ball Lock® T-Columns

- Class 40 Cast Iron
- Also available in Aluminum
- Ball Lock® Receiver Bushings and Liners installed
- Provides accurate fixturing base for CNC machining centers
- Perpendicularity is 0.025 mm per 250 mm

Custom Sizes Available with or without Ball Lock®
 We are able to quote you on your special requirement with or without the Ball Lock® Mounting System.
 Call 1-877-426-2504 for design specification information.

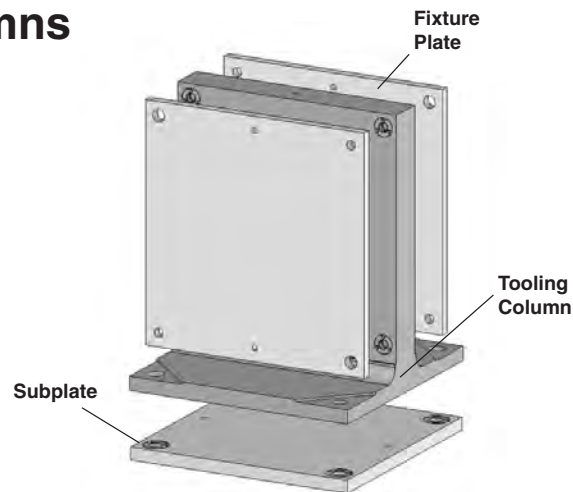

Cast Iron T-Columns With Ball Lock® Receiver Bushings Installed

See page 34 for Metric Fixture Plates and Subplates

Pallet Size (mm)	Part Number	C (mm)	D (mm)	E (mm)	F (mm)	G (mm)	H (mm)	I (mm)	J (mm)	K (mm)	L (mm)	M (mm)	N (mm)	O (mm)	P (mm)	Wt. (kg)
400	69151	410	25	400	400	350	350	350	350	100	500	125	90	20	20	190
500	69161	560	25	500	500	475	425	425	425	120	650	137.5	90	25	25	310
630	69171	660	40	630	630	575	550	525	525	100	750	137.5	90	35	25	500

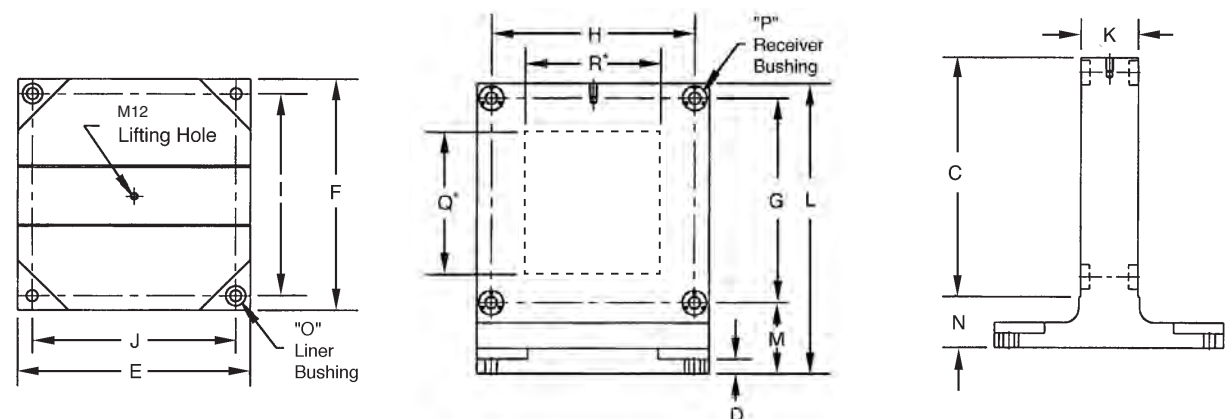

*Note: Window sections are also available on T-Columns. Specify window size and location (Q and R Dimensions).

Corresponding Fixture Plates, Subplates and Ball Lock® Shanks

Pallet Size (mm)	T-Column Part Number	Aluminum Fixture Plate Part Number	Steel Fixture Plate Part Number	Fixture Plate Size	Fixture Plate Ball Lock® Shank Part Number	Shank Size	Subplate Part Number	Subplate Ball Lock® Shank Part Number	Shank Size
400	69151	58717	58817	400 x 400	49651	20 x 20	59102	49652	20 x 25
500	69161	58745	58845	500 x 550	49662	25 x 25	59103	49662	25 x 25
630	69171	58746	58846	625 x 650	49662	25 x 25	59104	49683	35 x 40

Use Hoist Ring **23462**, see Lifting Solutions Catalog or Master Catalog for lifting and handling – Order separately.

Engineering Changes
 Product improvement is a continuing process at Jergens. Specifications and engineering data are subject to change after publishing. Contact Jergens Technical Sales Department to verify any dimensions or specifications.

Pre-Machined Ball Lock® 4-Sided Tooling Columns

- Class 40 cast iron
- Also available in Aluminum
- Ball Lock® Receiver Bushings and Liner Bushings installed
- Provides accurate fixturing base for CNC machining centers
- Perpendicularity is 0.025 mm per 250 mm

Custom Sizes Available with or without Ball Lock®

We are able to quote you on your special requirement with or without the Ball Lock® Mounting System.

Call 1-877-426-2504 for design specification information.

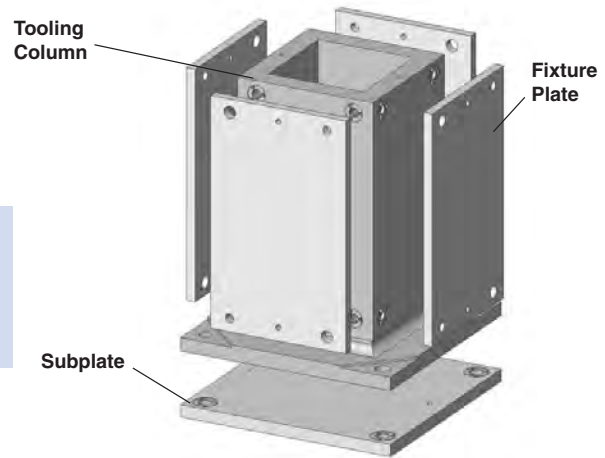

Cast Iron 4-Sided Tooling Columns With Ball Lock® Receiver Bushings Installed

See page 32 for Metric Fixture and Subplates

Pallet Size (mm)	Part Number	A (mm)	B (mm)	C (mm)	D (mm)	E (mm)	F (mm)	G (mm)	H (mm)	I (mm)	J (mm)	K (mm)	L (mm)	M (mm)	N (mm)	O (mm)	P (mm)	Wt. (kg)
400	69051	250	250	505	25	400	400	450	150	350	350	40	600	125	95	20	20	225
500	69061	300	300	630	25	500	500	550	175	425	425	40	725	137.5	95	25	25	320
630	69071	400	400	655	40	630	630	575	275	525	525	45	750	137.5	95	35	25	495

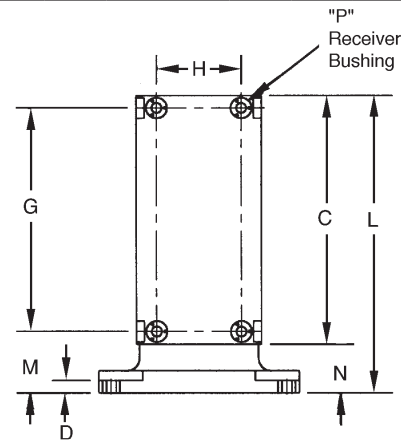
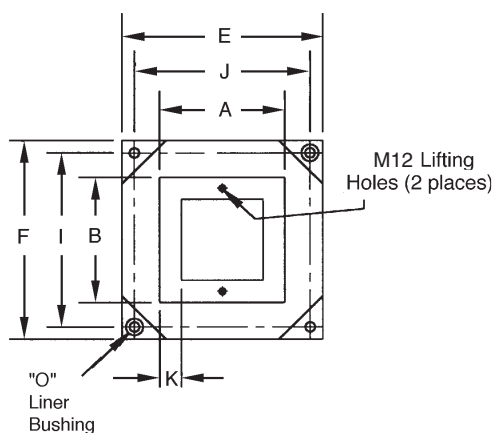

Corresponding Fixture Plates, Subplates and Ball Lock® Shanks

Pallet Size (mm)	T-Column Part Number	Aluminum Fixture Plate Part Number	Steel Fixture Plate Part Number	Fixture Plate Size	Fixture Plate Ball Lock® Shank Part Number	Shank Size	Subplate Part Number	Subplate Ball Lock® Shank Part Number	Shank Size
400	69051	58741	58841	250 x 500	49651	20 x 20	59102	49652	20 x 25
500	69061	58742	58842	300 x 625	49662	25 x 25	59103	49662	25 x 25
630	69071	58743	58843	400 x 650	49662	25 x 25	59104	49683	35 x 40

Use Hoist Ring **23462**, see Lifting Solutions Catalog or Master Catalog for lifting and handling – Order separately.

Engineering Changes

Product improvement is a continuing process at Jergens. Specifications and engineering data are subject to change after publishing. Contact Jergens Technical Sales Department to verify any dimensions or specifications.

Subplates for Tooling Columns and Fixture Plates

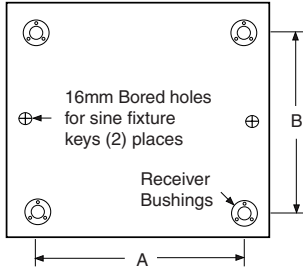

Standard Steel Subplates for Tooling Columns

Subplate Mounting holes can be provided per customer specification. Supplied with Ball Lock® Receiver Bushings installed.

Part Number	Pallet Size (mm)	For Tooling Columns	Ball Lock® Pattern		Receiver Size (mm)	Thickness of Subplate (mm) ±0.13	Wt. (Kgs)
			A (mm)	B (mm)			
59102	400	69151, 69051	350	350	20	28.57	31
59103	500	69161, 69061	425	425	25	31.75	59
59103-C	500	69151, 69051	350/425	350/425	20/25	31.75	59
—	—	69161, 69061	Dual	Dual	Dual	—	—
59104	630	69171, 69071	525	525	35	34.92	124

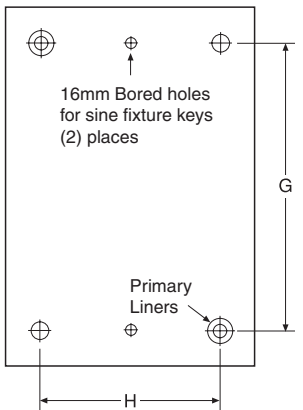

Fixture Plates for Standard Tooling Columns and T-Columns

Supplied with 2 primary Ball Lock® Liner Bushings installed.

Pallet Size (mm)	Part Number				For Tooling Columns	Type	Fixture Plate Size (mm)	Fixture Plate Thickness (mm) ±0.13	Ball Lock® Pattern		Liner Size (mm)
	Aluminum	(kg)	Steel	(kg)					H (mm)	G (mm)	
400	58741	7	58841	19	69051	4-S	250x500	20	150	450	20
500	58742	13	58842	36	69061	4-S	300x625	25	175	550	25
630	58743	18	58843	50	69071	4-S	400x650	25	275	575	25
400	58717	8	58817	25	69151	T	400x400	20	350	350	20
500	58745	19	58845	53	69161	T	500x550	25	425	475	25
630	58746	27	58846	63	69171	T	625x650	25	550	575	25

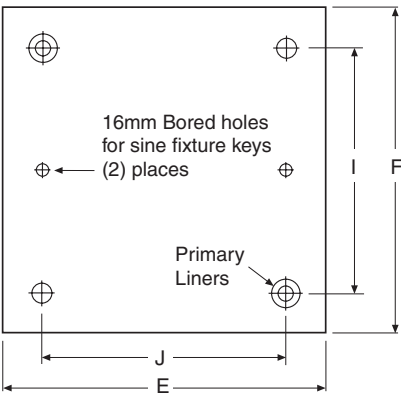

Fixture Plates for Tooling Column Subplates

Supplied with 2 primary Ball Lock® Liner Bushings installed.

Pallet Size (mm)	Part Number				For Subplate	Plate Dim.		Fixture Plate Thickness ±0.13 (mm)	Ball Lock® Pattern		Liner Size (mm)
	Aluminum	(kg)	Steel	(kg)		E (mm)	F (mm)		I (mm)	J (mm)	
400	58717	8	58817	25	59102	400	400	20	350	350	20
500	58727	17	58827	48	59103	500	500	25	425	425	25
630	58732	27	58832	76	59104	630	630	25	525	525	35

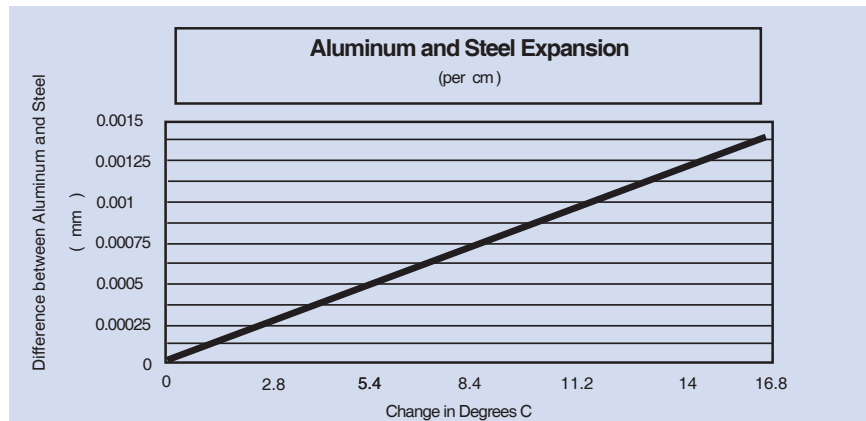

NOTE: Aluminum and steel expand at different rates. Please take this information into consideration when creating your own Ball Lock® fixture and subplates.

Ball Lock® For 4th Axis Rotary Indexers

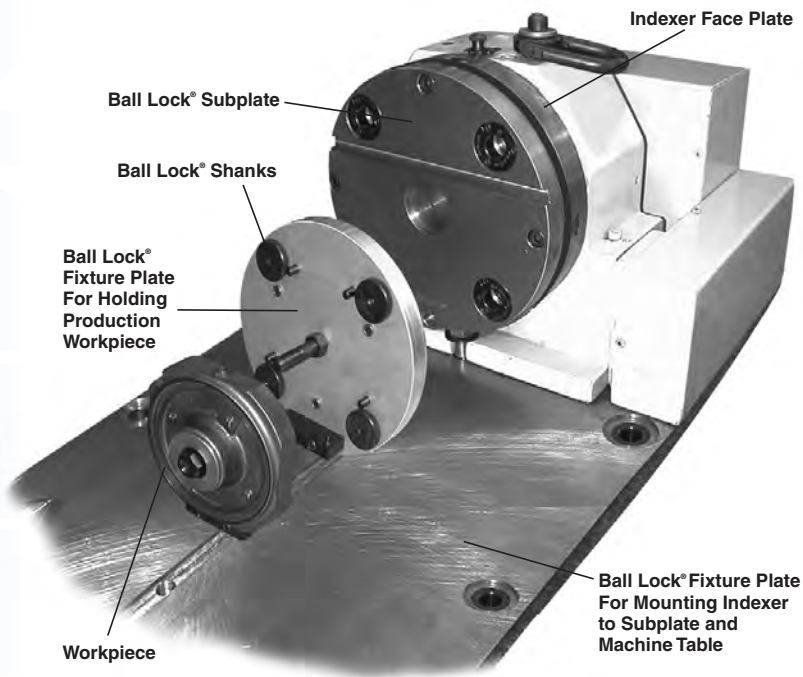
Problem:

Rotary indexers increase the versatility of vertical machining centers, yet they offer one major challenge: set-up is so time-consuming that it may limit a machine's flexibility. In many cases, machinists dedicate their 4th Axis tool to a single machine to avoid the agony of an extended set-up and changeover.

Benefits:

- Maximize indexer utilization
- Eliminate lengthy set-ups
- Accurate fixture plate changeover in seconds

Jergens' Solution:

Ball Lock® Mounting System for Indexers provides a double solution.

First, Ball Lock® mounting plates free up your machine for additional work by allowing a fast and accurate installation and removal of the complete indexer. Avoid hours of set up. The Ball Lock® System does it in minutes, with repeatability at $\pm 0.0005"$ ($\pm 0.013\text{mm}$). Low profile, positive clamping, proven in over many years of field use.

Second, the Ball Lock® System provides your fixture plate changeover. By mounting the round subplate to the indexer faceplate, you'll "plug-in" new fixtures in record time (less than 60 seconds).

Subplates and fixture plates come with bushings pre-installed.

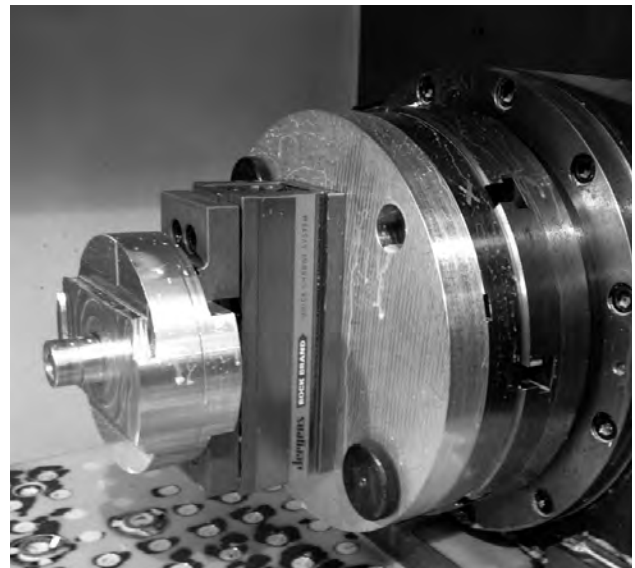
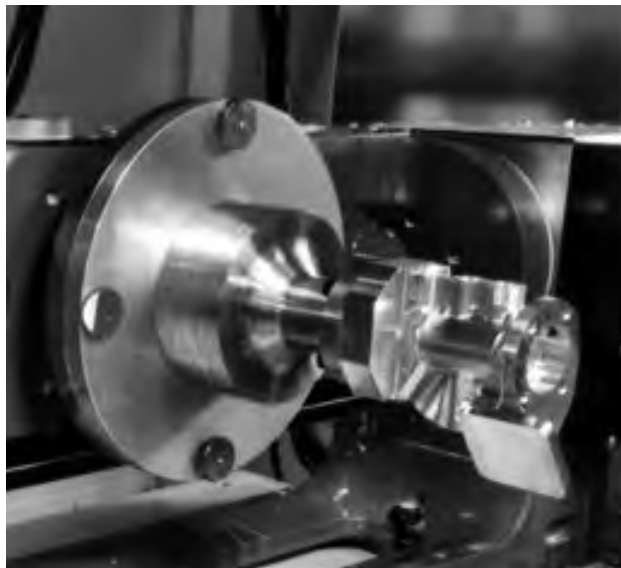

Round Ball Lock® Fixture Plates and Subplates

Standard Round

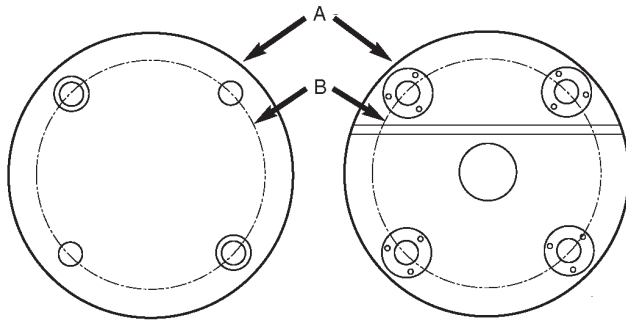

Fixture Plate

Subplate

Cast Aluminum, FreeMax™ or Steel equivalent

Fixture Plate (mm)

Part Number	A (mm)	B (mm)	Thickness (mm)	Ball Lock® Liner (mm)	Ball Lock® Shank	Weight (Kgs)
58707	200	150	20	16	49657	1.6
58708	250	200	25	20	49652	3.2
58709	300	250	25	20	49652	5.0

Subplate (mm)

Part Number	A (mm)	B (mm)	Thickness (mm)	Ball Lock® Receiver (mm)	Center Hole (mm)	Weight (Kgs)
59107	200	150	20	16	25	5
59108	250	200	25	20	50	9.6
59109	300	250	25	20	50	15

Note: Equivalent system available in inch dimensions.

Custom Round Plates

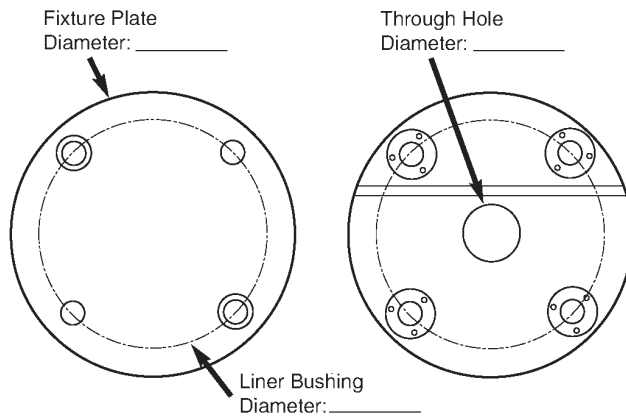

- Cast Aluminum or FreeMax™ is steel or equivalent
- Thickness ± 0.13mm
- Parallel within 0.025mm Steel

Indexer:

Make: _____
 Model: _____
 Diameter: _____
 Light Duty or Heavy Duty: _____
 Through Hole Bore: _____

CNC Machine:

Make: _____
 Model: _____
 Weight Capacity: _____

Indexer Faceplate:

T-Slot Size: _____
 Configuration/Orientation: _____
 or
 Drilled Tapped Hole Size: _____
 Configuration/Orientation: _____

Engineering Changes

Product improvement is a continuing process at Jergens. Specifications and engineering data are subject to change without notice. If current information is critical to your design, it is suggested that you contact Jergens Technical Sales Department to verify any dimensions or specifications.

METRIC

QUICK CHANGE FIXTURING » BALL LOCK® MOUNTING SYSTEM

METRIC

Locating and Clamping Shanks



U.S. Patents: 3,498,653
4,135,418

- Material: Shank/Bushing, AISI 4340
Liner, 52100
- Finish: Black Oxide
- Heat Treat: Shanks, RC 40-45
Bushings, RC 50-54
Liners, RC 62-64

• Operating Temperature Range:
-30°C to 200°C

- Stainless Steel available.
See Page 39-40.

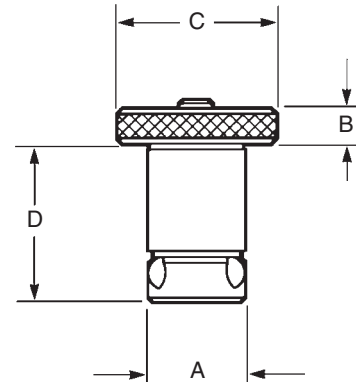

Repair Kits



Each Kit Includes:

- Replacement Screw
- Locking Balls
- Drive Ball
- O-Ring

Any Ball Lock® application requires at least two sets of shanks, receiver bushings and liners. The liners are placed into the fixture plate to insure extremely accurate positioning. If more than two shanks are required (to provide additional hold down force), omit the liner bushing so that these additional holes will not interfere with your primary locating holes.

See page 41 for Fast Acting Shanks.

Locating and Clamping Shank Dimensions

Shank Diameter (mm) A	Fixture Plate Thickness ±0.13mm	Shank Part Number	Head of Shank		D	Hex Wrench Size For Set Screw	Maximum		Recommended		Shank Repair Kit Part Number
			Height B	Diameter C			Screw Torque (N.m)	Holddown Force (KN)	Screw Torque (N.m)	Holddown Force (KN)	
13	13	49655	6	22	27.6	2.5	1.2	3.3	1	2.7	49955
—	20	49656	—	—	34.6	—	—	—	—	—	49956
16	20	49657	8	32	36.5	3	4.5	5.3	3	3.5	49957
—	25	49658	—	—	41.5	—	—	—	—	—	49958
20	20	49651	10	40	39.5	3	5.3	13.3	4	10	49951
—	25	49652	—	—	44.5	—	—	—	—	—	49952
25	20	49661	10	45	44.0	4	11	30	9	23	49961
—	25	49662	—	—	49.0	—	—	—	—	—	49962
30	20	49671	13	50	49.0	5	18	44	15	35	49971
—	25	49672	—	—	54.0	—	—	—	—	—	49972
35	20	49681	13	60	51.0	6	33	68	25	52	49981
—	25	49682	—	—	56.0	—	—	—	—	—	49982
—	40	49683	—	—	71.0	—	—	—	—	—	49983
—	50	49684	—	—	81.0	—	—	—	—	—	49984
50	20	49691	20	75	64.0	10	65	88	50	67	49991
—	25	49692	—	—	69.0	—	—	—	—	—	49992
—	40	49693	—	—	84.0	—	—	—	—	—	49993
—	50	49694	—	—	94.0	—	—	—	—	—	49994

Receiver Bushings

Two styles of receiver bushings are available. Installed bushings should be approximately 0.3mm below subplate surface.



Face Mount

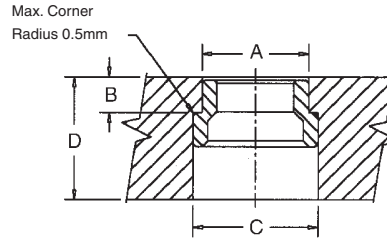
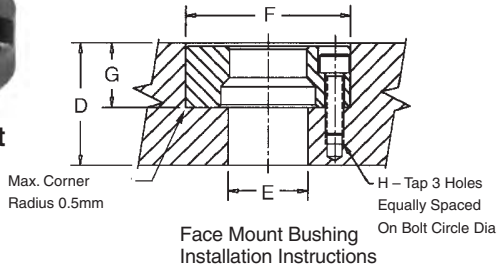

Back Mount

Back Mount Bushing Installation Instructions

Generally, the face mount receiver bushing is utilized in blind hole applications (Slip Fit).

The back mount receiver bushing is used in through hole applications (Light Press Fit).

Installation Dimensions

Face Mount

Shank Dia. (mm)	Face Mount Part Number	Actual O.D. -0.01 -0.02	Clearance Drill Diameter E	Bore +0.010 +0.003 F	Depth +0.025 -0.025 G	Tap Size & Depth ¹ H	Bolt Circle Diameter 3 PL Equally Spaced	Min. Subplate Thickness D
13	49556	35	13.5	35	11.91	M4x0.7 x 7	25	20
16	49557	37	21.0	37	11.91	M4x0.7 x 7	29	20
20	49551	45	21.0	45	16.21	M5x0.8 x 9	35	25
25	49552	55	25.5	55	20.32	M6x1.0 x 10	42	30
30	49553	60	30.5	60	22.15	M6x1.0 x 11	48	35
35	49554	70	40.0	70	22.99	M8x1.25 x 17	56	40
50	49555	92	55.0	92	31.50	M10x1.5 x 18	75	50

Back Mount

Shank Dia. (mm)	Back Mount Part Number	Actual O.D. +0.04 +0.03 A	Depth +0.025 -0.025 B	C-Bore ±0.15 C	Min. Subplate Thickness D
13	49566	20	6.92	26	20
16	49567	22	7.24	29	20
20	49561	28	8.74	33	25
25	49562	35	10.54	41	25
30	49563	42	10.95	49	30
35	49564	48	12.50	55	35
50	49565	67	15.75	76	45

¹Cap Screws Supplied with Face Mount Bushings.

Liner Bushings for Fixture Plates



Locating repeatability will determine if one primary and one secondary or two primary liners are needed. With two primary liners, repeatability of ±0.013 mm can be maintained if the two holes for receiver bushings are held to a centerline distance of ±0.005 mm tolerance.

Note on Installation of Press Fit Liners & Back Mount Style Receiver Bushings:

To alleviate the possibility of binding the shank in the bore, the maximum interference fit between bore and bushing O.D. should not exceed 0.013 mm.

Shank Diameter (mm)	Fixture Plate Thickness +0.13 -0.13	Primary Liner		Secondary Liner		Liner O.D. +0.00 -0.01
		Part Number	I.D.	Part Number	I.D.	
13	13	49755	13.01	49855	13.04	19.040
—	20	49756	—	49856	—	19.040
16	20	49757	16.01	49857	16.04	25.042
—	25	49758	—	49858	—	25.042
20	20	49751	20.01	49851	20.04	35.042
—	25	49752	—	49852	—	35.042
25	20	49761	25.01	49861	25.04	35.042
—	25	49762	—	49862	—	35.042
30	20	49771	30.01	49871	30.04	45.042
—	25	49772	—	49872	—	45.042
35	20	49781	35.01	49881	35.04	45.042
—	25	49782	—	49882	—	45.042
—	40	49783	—	49883	—	45.042
—	50	49784	—	49884	—	45.042
50	20	49791	50.01	49891	50.04	63.546
—	25	49792	—	49892	—	63.546
—	40	49793	—	49893	—	63.546
—	50	49794	—	49894	—	63.546

METRIC

QUICK CHANGE FIXTURING » BALL LOCK® MOUNTING SYSTEM

METRIC

Stainless Steel Locating and Clamping Shanks



- Material: 17-4 PH Stainless Steel
- Heat Treat: Rc 40-45
- Operating Temperature Range: -30°C to 200°C

U.S. Patents: 3,498,653
4,135,418

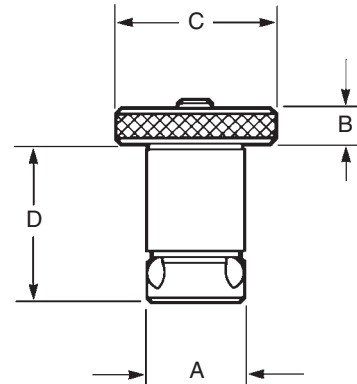

Replacement Kits



Each Kit Includes:

- Replacement Screw
- Locking Balls
- Drive Ball
- O-Ring

Any Ball Lock® application requires at least two sets of shanks, receiver bushings and liners. The liners are placed into the fixture plate to insure extremely accurate positioning. If more than two shanks are required (to provide additional hold down force), omit the liner bushing so that these additional holes will not interfere with your primary locating holes.

Stainless Steel Locating and Clamping Shank Dimensions

Shank Diameter (mm) A	Fixture Plate Thickness ±0.13mm	Shank Part Number	Head of Shank		D	Hex Wrench Size For Set Screw	Maximum		Recommended		Shank Repair Kit Part Number
			Height B	Diameter C			Screw Torque (N.m)	Holddown Force (KN)	Screw Torque (N.m)	Holddown Force (KN)	
13	13	49655SS	6	22	27.6	2.5	1.2	3.3	1	2.7	49955SS
—	20	49656SS	—	—	34.6	—	—	—	—	—	49956SS
16	20	49657SS	8	32	36.5	3	4.5	5.3	3	3.5	49957SS
—	25	49658SS	—	—	41.5	—	—	—	—	—	49958SS
20	20	49651SS	10	40	39.5	3	5.3	13.3	4	10	49951SS
—	25	49652SS	—	—	44.5	—	—	—	—	—	49952SS
25	20	49661SS	10	45	44.0	4	11	30	9	23	49961SS
—	25	49662SS	—	—	49.0	—	—	—	—	—	49962SS
30	20	49671SS	13	50	49.0	5	18	44	15	35	49971SS
—	25	49672SS	—	—	54.0	—	—	—	—	—	49972SS
35	20	49681SS	13	60	51.0	6	33	68	25	52	49981SS
—	25	49682SS	—	—	56.0	—	—	—	—	—	49982SS
—	40	49683SS	—	—	71.0	—	—	—	—	—	49983SS
—	50	49684SS	—	—	81.0	—	—	—	—	—	49984SS
50	20	49691SS	20	75	64.0	10	65	88	50	67	49991SS
—	25	49692SS	—	—	69.0	—	—	—	—	—	49992SS
—	40	49693SS	—	—	84.0	—	—	—	—	—	49993SS
—	50	49694SS	—	—	94.0	—	—	—	—	—	49994SS

Stainless Steel Receiver Bushings

Two styles of receiver bushings are available. Installed bushings should be approximately 0.3mm below subplate surface.



Face Mount

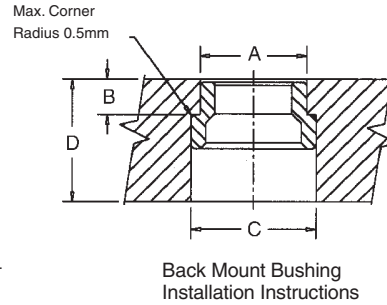
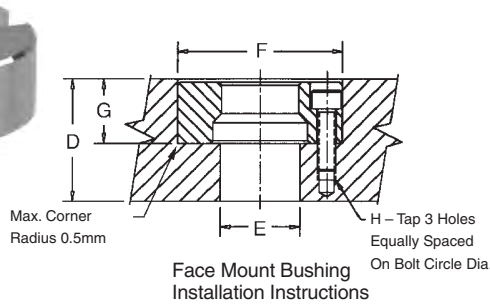

Back Mount

Generally, the face mount receiver bushing is utilized in blind hole applications (Slip Fit).

The back mount receiver bushing is used in through hole applications (Light Press Fit).

Installation Dimensions

Face Mount

Shank Dia. (mm)	Face Mount Part Number	Actual O.D. -0.01 -0.02	Clearance Drill Diameter E	Bore +0.010 +0.003 F	Depth +0.025 -0.025 G	Tap Size & Depth ¹ H	Bolt Circle Diameter 3 PL Equally Spaced	Min. Subplate Thickness D
13	49556SS	35	13.5	35	11.91	M4x0.7 x 7	25	20
16	49557SS	37	21.0	37	11.91	M4x0.7 x 7	29	20
20	49551SS	45	21.0	45	16.21	M5x0.8 x 9	35	25
25	49552SS	55	25.5	55	20.32	M6x1.0 x 10	42	30
30	49553SS	60	30.5	60	22.15	M6x1.0 x 11	48	35
35	49554SS	70	40.0	70	22.99	M8x1.25 x 17	56	40
50	49555SS	92	55.0	92	31.50	M10x1.5 x 18	75	50

Back Mount

Shank Dia. (mm)	Back Mount Part Number	Actual O.D. +0.04 +0.03 A	Depth +0.025 -0.025 B	C-Bore ±0.15 C	Min. Subplate Thickness D
13	49566SS	20	6.92	26	20
16	49567SS	22	7.24	29	20
20	49561SS	28	8.74	33	25
25	49562SS	35	10.54	41	25
30	49563SS	42	10.95	49	30
35	49564SS	48	12.50	55	35
50	49565SS	67	15.75	76	45

¹Cap Screws Supplied with Face Mount Bushings.

Stainless Steel Liner Bushings for Fixture Plates



Locating repeatability will determine if one primary and one secondary or two primary liners are needed. With two primary liners, repeatability of ±0.013 mm can be maintained if the two holes for receiver bushings are held to a centerline distance of ±0.005 mm tolerance.

Note on Installation of Press Fit Liners & Back Mount Style Receiver Bushings:

To alleviate the possibility of binding the shank in the bore, the maximum interference fit between bore and bushing O.D. should not exceed 0.013 mm.

Liner Dimensions

Shank Diameter (mm)	Fixture Plate Thickness +0.13 -0.13	Primary Liner		Secondary Liner		Liner O.D. +0.00 -0.01
		Part Number	I.D.	Part Number	I.D.	
13	13	49755SS	13.01	49855SS	13.04	19.040
—	20	49756SS	—	49856SS	—	19.040
16	20	49757SS	16.01	49857SS	16.04	25.042
—	25	49758SS	—	49858SS	—	25.042
20	20	49751SS	20.01	49851SS	20.04	35.042
—	25	49752SS	—	49852SS	—	35.042
25	20	49761SS	25.01	49861SS	25.04	35.042
—	25	49762SS	—	49862SS	—	35.042
30	20	49771SS	30.01	49871SS	30.04	45.042
—	25	49772SS	—	49872SS	—	45.042
35	20	49781SS	35.01	49881SS	35.04	45.042
—	25	49782SS	—	49882SS	—	45.042
—	40	49783SS	—	49883SS	—	45.042
—	50	49784SS	—	49884SS	—	45.042
50	20	49791SS	50.01	49891SS	50.04	63.546
—	25	49792SS	—	49892SS	—	63.546
—	40	49793SS	—	49893SS	—	63.546
—	50	49794SS	—	49894SS	—	63.546

Accessories

Tapered Caps and Plugs

Keep debris out of your subplate's receiver bushings when not in use. Polyethylene caps snap in and out easily.



Packaged 10 per pack.

Receiver Bushing Diameter	Part Number
13	49201
16	49202
20	49203
25	49204
30	49205
35	49206
50	49207



Lifting Handles

For easy handling of fixture plates up to 500 lbs.

Part Number	Length	Ht.	W	Mounting Distance
33701	107mm	36mm	.38 Kg	93.47mm

Multi-Slot Sine Fixture Keys



Locate subplates or fixture plates to slotted machine tables without having to slot the plate. Available in sizes from 12mm to 32mm slots.

Part Number	Shank Size A	Key Width			Wt. (lbs)	Recommended Hole Dia.
		B	C	D		
39525	16	10	20	—	0.04	16mm Shank Size 16.01 +/-0.01
39526	16	12	22	—	0.04	16mm Shank Size 16.01 +/-0.01
39527	16	14	16	18	0.04	16mm Shank Size 16.01 +/-0.01
39528	20	24	28	32	0.09	20mm Shank Size 20.01 +/-0.01

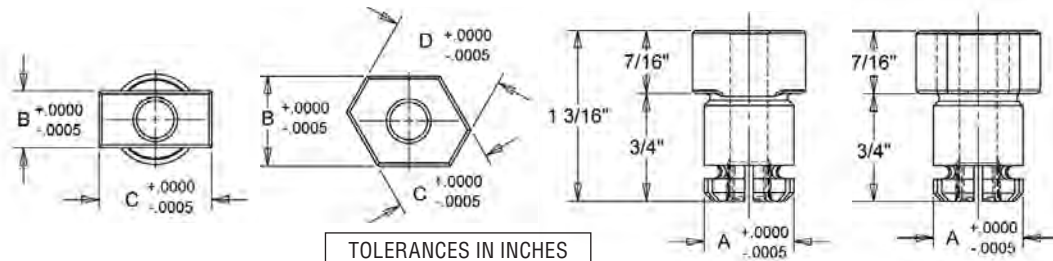

Fast Acting Ball Lock® Shanks

Ball Lock® Shank Diameter (mm)	Fixture Plate Thickness (mm)	FAST ACTING BALL LOCK® SHANKS			
		Shank with Thumb Screw		Shank with Adjustable Handle	
		Part Number		Part Number	
		Assembly	T-Screw	Assembly	Handle
13	13	49655-S	43971	49655-H	34360
—	20	49656-S	43972	49656-H	34361
16	20	49657-S	43974	49657-H	34365
—	25	49658-S	43975	49658-H	34365
20	20	49651-S	43974	49651-H	34365
—	25	49652-S	43975	49652-H	34365
25	20	49661-S	43977	49661-H	34378
—	25	49662-S	43978	49662-H	34379
30	20	49671-S	43980	49671-H	34385
—	25	49672-S	43980	49672-H	34385
35	20	49681-S	43985	49681-H	34393
—	25	49682-S	43985	49682-H	34393



Thumb Screw

- Fast acting thumb screws 2 1/2 turns. No tools needed.



Adjustable Handle

- Handle can be moved out of the work area to avoid interference.

Receiver Bushing Plugs



- Material: Aluminum
- Finish: Blue Anodize
- O-Ring Included
- Prevent chips and coolant from accumulating inside receiver bushings that are not in use
- Eliminates the need to clean out receiver bushings in between setups
- Flush mount design does not protrude above subplate surface
- Durable aluminum construction provides better resistance to hot chips than comparable plastic plugs
- Tapped hole for easy removal

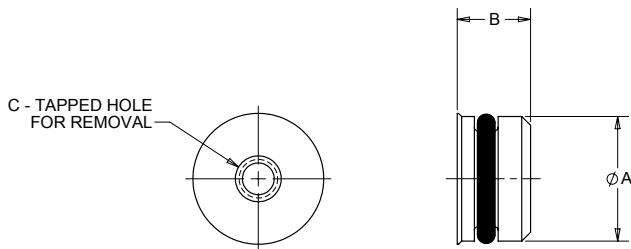

Bushing Dia. (mm)	Plug Part Number	A (mm)	B (mm)	C	Extraction Tool Part No.
13	49231	13	8	M4 x 0.7	49208
16	49232	16	8	M4 x 0.7	49208
20	49233	20	8	M4 x 0.7	49208
25	49234	25	10	M4 x 0.7	49208
30	49235	30	11	M4 x 0.7	49208
35	49236	35	14	M6 x 1.0	49209
50	49237	50	17	M6 x 1.0	49209



Quick Change Kits

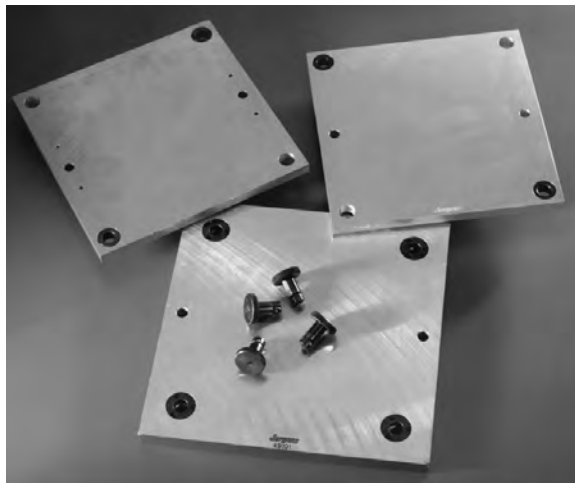

The Jergens Ball Lock® Quick Change Kits speed fixture changeover in all types of manufacturing operations. Each kit includes two aluminum fixture plates with 2 primary liner bushings installed; one steel subplate with receiver bushings installed, and four 20mm Ball Lock® shanks with working loads of 3000 lbs. each. While one fixture plate is on the machine, the operator can load parts on the other. This minimizes downtime for true set-up reduction. To enable the subplate to be mounted on a slotted table without the need to indicate the subplate, sine fixture keys can be used. The sine fixture key reamed holes are oriented parallel to the receiver bushings on the subplate and to the liner bushings on the fixture plate. These also allow the fixture plate to be mounted on a toolroom mill without the need to indicate it. This is extremely useful when machining location points on your fixture.



Everything You Need to Change Fixtures in Less Than One Minute

Aluminum Fixture Plate

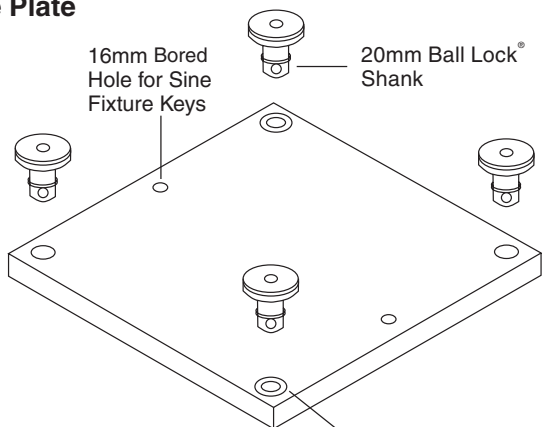

Steel Subplate

16mm Bored Hole for Sine Fixture Keys

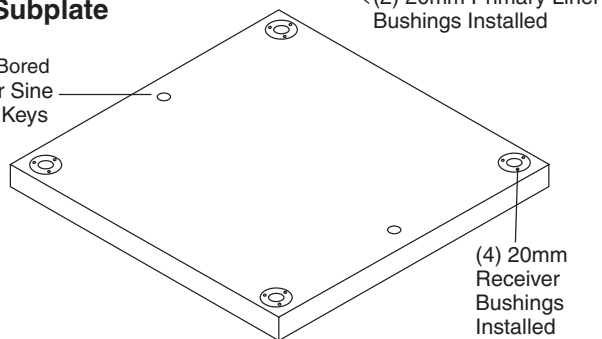

Quick Change Kits

Part Number	Kit Includes
59002	2 - 58715 (400x400x20) aluminum fixture plates with 20mm liner bushings installed 1 - 59101 (400x400x25) steel subplate with receiver bushings installed 4 - 20mm Ball Lock® Shanks (49651)

Custom Kits Available

Jergens manufactures ready to use kits including Ball Lock® subplate and fixture plates.

For a special kit tailored to your CNC machine, please provide:

Name and Type of Machine _____
 Travel of Machine Table (x, y, z) _____
 Dimensions of Machine Table (x and y) _____
 Maximum Weight allowed on Machine Table _____
 T-slot Width and Center to Center Distance _____